

multicube

*Modular Metering System
Operating and Installation Manual*



Revision 1.01

Published January 2011

© Northern Design Metering Solutions

Modular Metering System - Description

1. Description

The **multicube** modular electricity metering System simultaneously monitors up to 20 three-phase loads or up to 60 single-phase loads (or a combination of both load types). The system integrates load measurement I/O functions logging and communications in a single, flexible unit which can be tailored to suit a variety of energy management installations.

A **multicube** system is built up from a combination of the following modular components:

- **1 Master Display Unit**
- **1-10 Option Modules**
 - Sub-Metering Modules (e.g. SM352*)
 - I/O Modules (eg Pulse Output Module(s) PM12)
- **1 Communications Module (e.g. Modbus RS485)**
- *** At least 1 sub metering module must be fitted.**

1.1. Master Display Unit

The Master Display Unit provides a user interface and local display of metered parameters on a graphic LCD and can optionally log up to 200 days of energy readings from the Sub-Metering Modules. The Master Display Unit also acts as a power supply and voltage measurement input for all the Sub-Metering Modules, which may be attached to it. This single voltage input point makes wiring much simpler and safer by removing the need for distributed voltage connections.

1.2. Dual Sub-Metering Module – SM352

The Electricity Metering Module **SM352** contains two complete 3-phase electricity meters, each of which may be optionally configured to monitor 3 single-phase loads. Each electricity meter accurately measures a wide range of power and energy parameters using a range of current input devices selected to suit loads with nominal inputs from 5 to 800 Amps. These specially designed transducers each have a nominal output of 0.33V, are safety-isolated and internally protected against high open-circuit voltages at the output. Split core current input devices can be fitted to existing power cables where it is inconvenient to remove one end of the cable for connection. Miniature ring type devices are also available for lower currents (up to 60A) providing a lower cost solution, with improved accuracy, where it is possible to slide these over one end of a power cable. Dual Sub-Metering Modules are configured using the Master Display Unit LCD/keypad interface or via the external communications network.

1.3. Communications Module

The Communications Module provides a connection point to external systems such as building energy management, billing data collection, SCADA etc. A specific Communications Module may be selected, such as the Modbus RTU - RS485 Module (RTU485), to suit a range of external systems. The Communications Module provides external access to:

- **Master Display Unit Configuration**
- **Master Display Unit Logged Data (Optional)**
- **Sub-Metering Module Instantaneous Meter Readings and Energy Registers**
- **Sub-Metering Module Configuration**
- **Additional Module Data and Configuration**

1.3.1. Further Information

Separate detailed guides are available for each type of communications module in the **multicube** range.

-

2. Safety

This instruction manual gives details of safe installation and operation of the **multicube** electricity metering system. Safety may be impaired if the instructions are not followed or the system is used in a manner not specified by the manufacturer. Labels give details of equipment ratings for safe operation. Take time to examine all labels before commencing installation. Safety symbols on the meter have specific meanings.

WARNING

Contains no user serviceable parts. Field wiring and commissioning should only be carried out by qualified personnel in compliance with applicable national regulations.

This product has been tested to the requirements of EN61010-1, 2nd Edition - including Amendment 1.

2.1. Maintenance

The equipment should be maintained in good working order. Damaged equipment must be returned to the manufacturer (or his authorised agent) for repair. The meter may be cleaned by wiping lightly with a soft cloth. No solvents or cleaning agents should be used. All inputs and supplies must be isolated before cleaning any part of the equipment.

multicube

Modular Metering System - Assembly

3. Multicube Systems Assembly

3.1. Building a New Multicube System

WARNING

Risk of Electric Shock!

Ensure all voltages are fully isolated before carrying out any installation work on the **multicube** system.

The following diagram shows how a standard **multicube system** is constructed on a length of 35mm Symmetrical DIN Rail. The order of assembly from left to right is always:

- LEFT HAND** Communications Module
 Master Display Unit
 0-9 Standard Modules (**SM352** or other)
- RIGHT HAND** End Dual Sub-Meter Module (**SM352-E**)

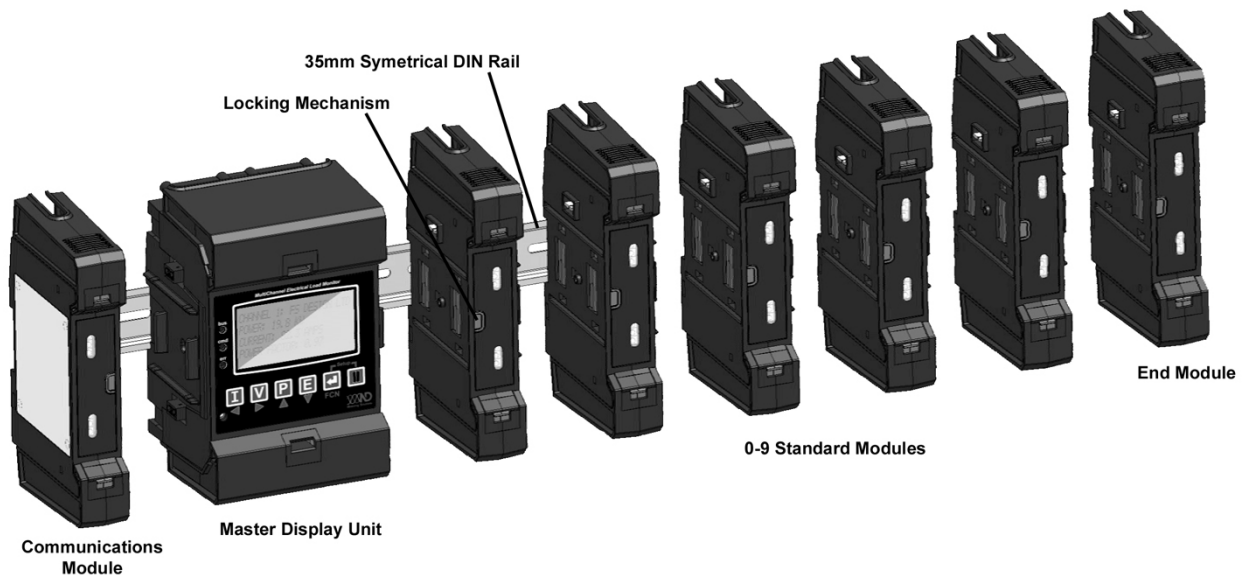

To Assemble a New **multicube** System:

- Place the communications module on the left hand end of the DIN rail.
- While pushing the Locking Mechanism attach the Master Display unit.
- Release the Locking Mechanism.
- Align the each module on the DIN Rail at the right hand end*.
- While pushing the Locking Mechanism slide the module to mate with the assembly.
- Release the Locking Mechanism.
- Add the right hand End Module as above.
- Check the Module is firmly attached by gently pulling apart.

* The last module fitted must be an End Module Type (eg SM352-E)

WARNING

Risk of Electric Shock!

Check the assembly carefully before applying power to the **multicube** System. Ensure all Modules are securely clipped together, check all wiring and tidy up.

3.2. Making Changes to an Existing Multicube System

WARNING

Risk of Electric Shock!

Ensure all voltages are fully isolated before carrying out any installation work on the **multicube** system.

3.2.1. Adding Modules

It is possible to upgrade a **multicube** system that has been previously configured (ref section 6) by adding new modules.

To Add a Module:

- Isolate all voltages to the system.
- Push the locking mechanism on the module to the right of the new module position.
- Pull the modules apart.
- Add the new module in the gap as described above.
- While pushing the Locking Mechanism add the remaining.
- Release the Locking Mechanism.
- Test that the modules are all fully engaged by attempting to pull apart.
- Check the installation and Power up the system.
- Configure the system to include the new module as described in Section 6.3.

NOTE: Reconfiguring the system clears all data from the data logger including accumulated tariff register totals. This process can be delayed until after the logged data is downloaded as described in Section 6.3.

3.2.2. Removing Modules

It is possible to upgrade a **multicube** system that has been previously configured (ref section 6) by removing existing modules.

To Remove a Module:

- Isolate all voltages to the system.
- Push the locking mechanism on the module to the right of the module being removed.
- Pull the modules apart.
- Push the locking mechanism on the module being removed.
- Slide the module to the right and remove from the DIN Rail.
- While pushing the Locking Mechanism push the remaining modules together.
- Release the Locking Mechanism.
- Test that the modules are all fully engaged by attempting to pull apart.
- Check the installation and Power up the system.
- Configure the system to include the new module as described in Section 6.3.

NOTE: Reconfiguring the system clears all data from the data logger including accumulated tariff register totals. This process can be delayed until after the logged data is downloaded as described in Section 6.3.

3.2.3. Replacing a Module

It is possible to replace a module in a **multicube** system with a new module of the same type. The system will recognise the change and provide the user with an option to automatically configure the new module to replace the original one while retaining the module settings, logged data and accumulated tariffs.

To Replace a Module:

- Remove the old module as described above (Removing Modules).
- Add the new Module as described above (Adding Modules)
- Pull the modules apart
- Check the installation and Power up the system.
- Configure the system to remove the old module as described in Section 6.3.

multicube

Modular Metering System - Installation

4. Installation

4.1. Intended Use

The **multicube** System simultaneously monitors up to 20 three-phase loads or up to 60 single-phase loads or a combination of both load types. The system is designed for connection to the following power networks:

- **3-Phase 3 or 4 Wire: Nominal 230V Phase to Neutral (400V Phase to Phase)**
- **Single Phase 2 Wire: Nominal 230V Phase to Neutral.**
- **Two Phase 3-Wire: Nominal 120V Phase to Neutral (240V Phase to Phase)**

The **multicube** should be mounted close to the power system distribution point to minimise the length of voltage and current input connections. Ensure that the voltage cable clamps are securely tightened and all terminal covers are securely fitted before powering up the system.

4.2. Mounting

The **multicube** is designed to be mounted on a 35mm symmetrical (“Top-Hat”) DIN rail. The minimum length of DIN Rail required depends on the number of standard modules fitted as follows:

Comms Module	Master Display Unit	Standard Modules	Right Hand End Module	Overall Length
29mm	100mm	0 = 0mm	29mm	158mm
29mm	100mm	1 = 29mm	29mm	187mm
29mm	100mm	2 = 58mm	29mm	216mm
29mm	100mm	3 = 87mm	29mm	245mm
29mm	100mm	4 = 116mm	29mm	274mm
29mm	100mm	5 = 145mm	29mm	303mm
29mm	100mm	6 = 174mm	29mm	332mm
29mm	100mm	7 = 203 mm	29mm	361mm
29mm	100mm	8 = 232mm	29mm	390mm
29mm	100mm	9 = 261mm	29mm	419mm

To clip the **multicube** on the DIN rail first hook onto the top of the rail then push the bottom of the unit till all the sprung clips click into place. For wall mounting the DIN rail should be first secured to the wall and the **multicube** system clipped on afterwards.

Modular Metering System - Installation

4.2.1. Access to Master Display Unit

The auxiliary mains supply and voltage input terminals are protected by a sliding terminal cover on the Master Display unit. To gain access to these terminals:



1. Insert a flat screwdriver into the slot at the front of the terminal cover.

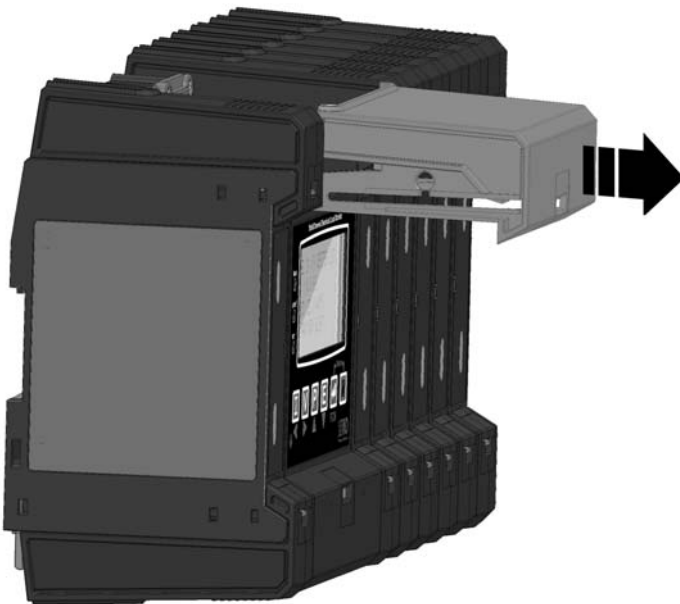

2. Slide the terminal cover forward to its full extent.
3. Hinge the cover down in front of the display.

NOTE: The screwdriver slot may be covered with a tamper evident label (20mm x 18mm) to detect unauthorized access.

Modular Metering System - Installation

4.2.2. Accessing Module Wiring Terminals

Module wiring terminals are protected by terminal covers as shown in the diagram below. The terminal covers are designed to slide towards the front of the module and are captive so they may not be removed and misplaced.

To access the terminals:

1. Push up the release clip using a tool.
2. Slide the terminal cover back to its full extent
3. Flip the terminal cover to lay in front of the module while accessing the wiring terminals.

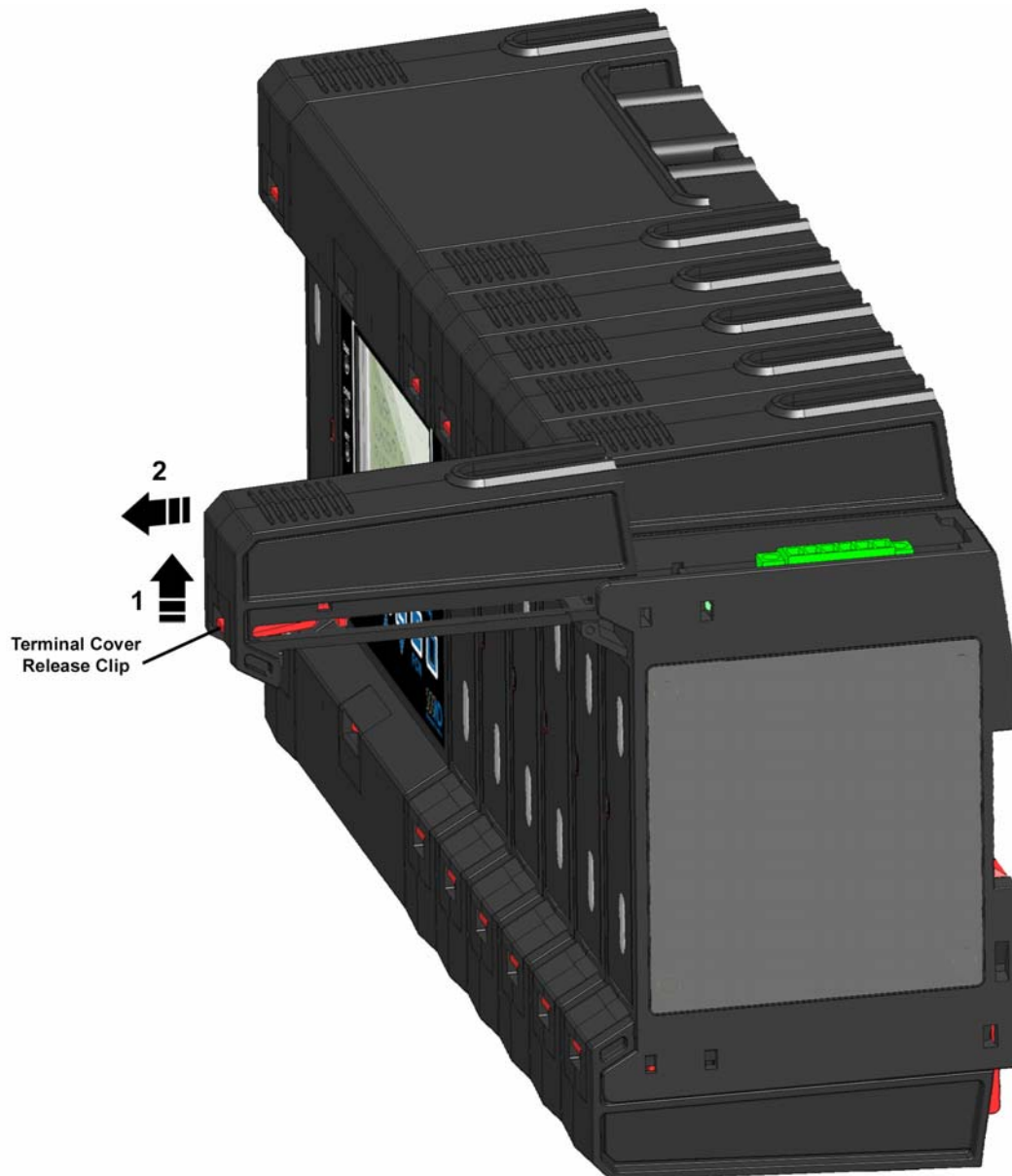

NOTE: The release clip may be covered with a tamper evident label (20mm x 18mm) to detect unauthorized access.

5. Schematics

Each ½ of an **SM352** Metering Module acts as an independent meter and can be configured during commissioning to monitor a three-phase load or three single-phase loads.

5.1. Voltage Inputs

Voltage measurement connections are common for all the slave meters and are made at the Master Display Unit. The voltage inputs are attenuated before being passed on to all metering modules. The voltage inputs and auxiliary mains supply to the system should be supplied from a suitably located and easily reached fused switch or circuit breaker included as part of the installation. This fused switch/circuit breaker must be marked as the disconnecting device for the equipment and must comply with the relevant requirements of IEC 60947-1 and IEC 60947-3.

The voltage input and auxiliary supply circuits must meet or exceed the following specification:

Cable: UL-1015; 600Vac; 105°C. 30-12AWG

Fuses (US/Canada)

Rated Voltage	Type	Rupture In (A)	Standards
≥500Vac	Time-Delay	1.0A	UL 248 (US) C22.2 No. 248 (CAN)

Fuses (Other Countries)

Rated Voltage	Type	Rupture In (A)	Standards
≥500Vac	Time-Delay	1.0A	IEC 60269-2

The auxiliary mains supply may be connected to any one of the measurement phases and system neutral as shown below (Phase 1 and Neutral shown).

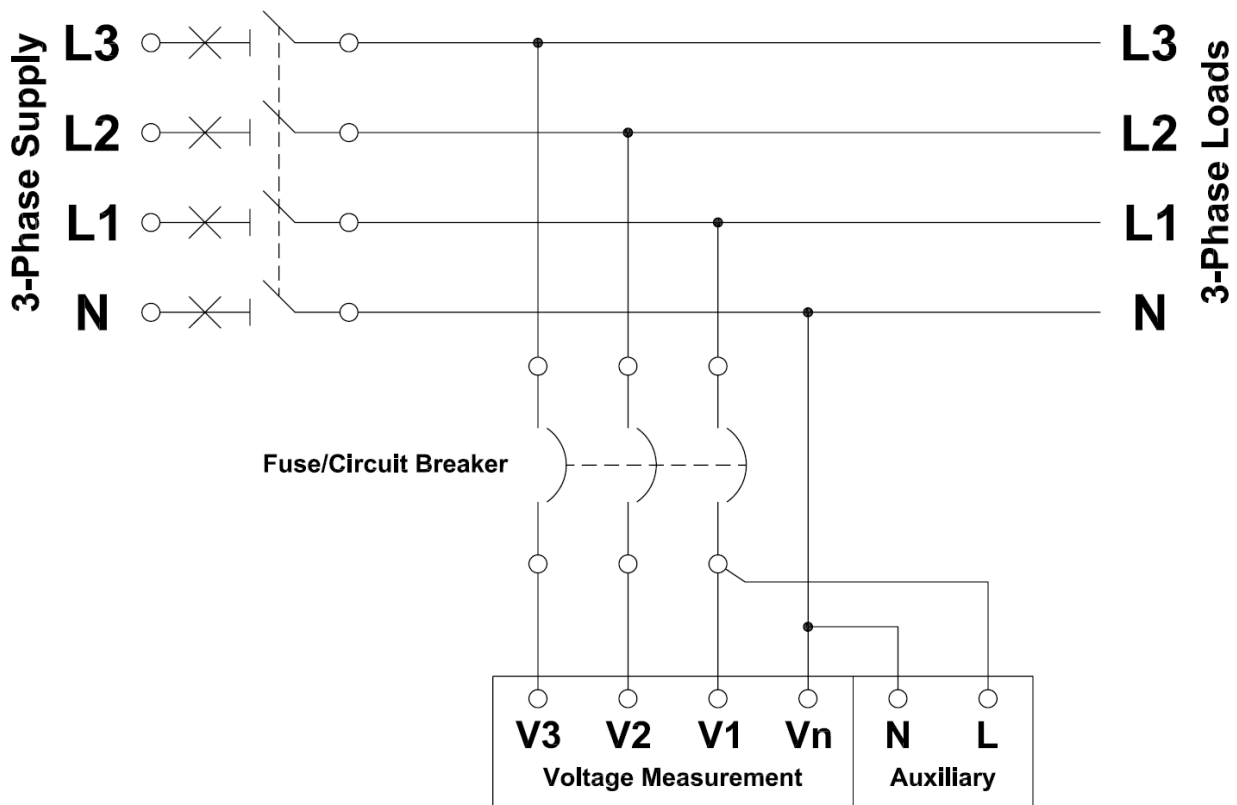

Figure 5-1 Auxiliary Mains and Measurement Voltage Inputs

5.2. Current Inputs SM352

Each phase current input of the **SM352** Sub-Metering Module is associated with one of three phase voltage inputs, which are supplied by the Master Display Unit. It is essential that current transducers are mounted on the correct associated voltage phase for accurate measurement.

To ensure safe operation, the Sub Metering Module **SM352** must only be used with Current Transducers supplied by the manufacturer. These provide an isolated 0.33Vac signal to the current inputs when measuring a nominal primary current. Current transducers must meet/exceed the following specification:

- **Case Isolation: 600Vac**
- **Internal Isolation: 2.11kV**
- **Operating Temperature Range: 0 to 60°C**
- **Cable: 105°C, 600Vac.**

Diagram of Various CTs with type Numbers

Figure 5-2 Current Transducer Types

5.3. Measuring 3 Phase Loads

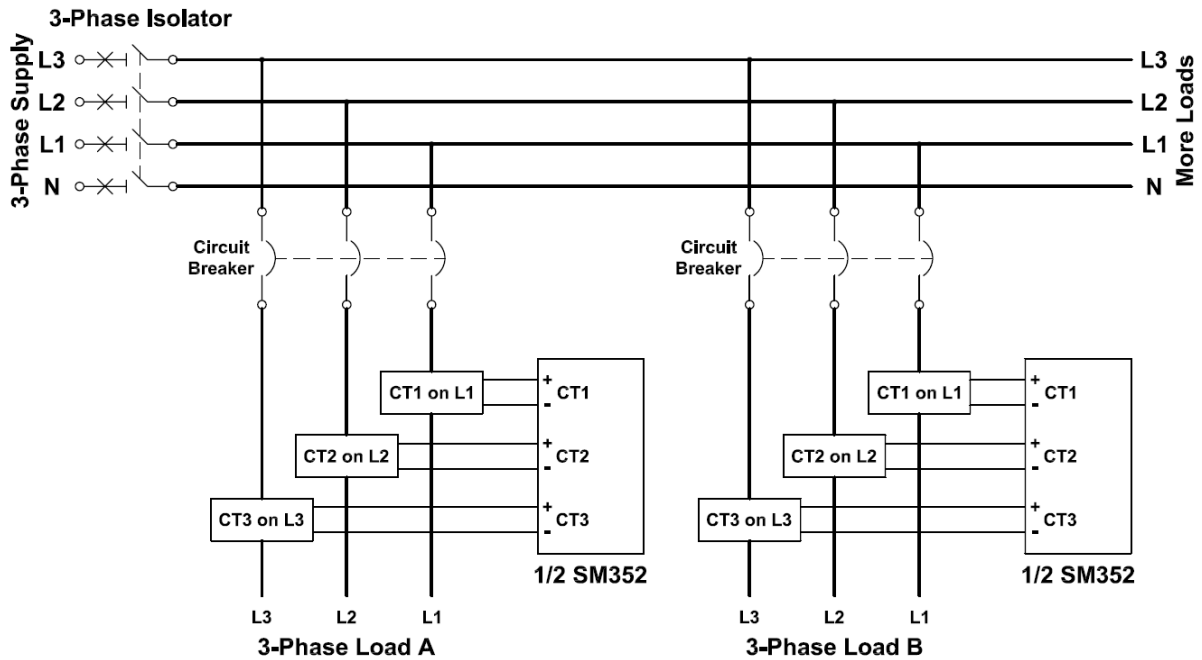

Figure 5-3 Measuring 2 x 3-Phase 3 or 4 Wire Loads on a SM352

5.4. Measuring Single Phase Loads

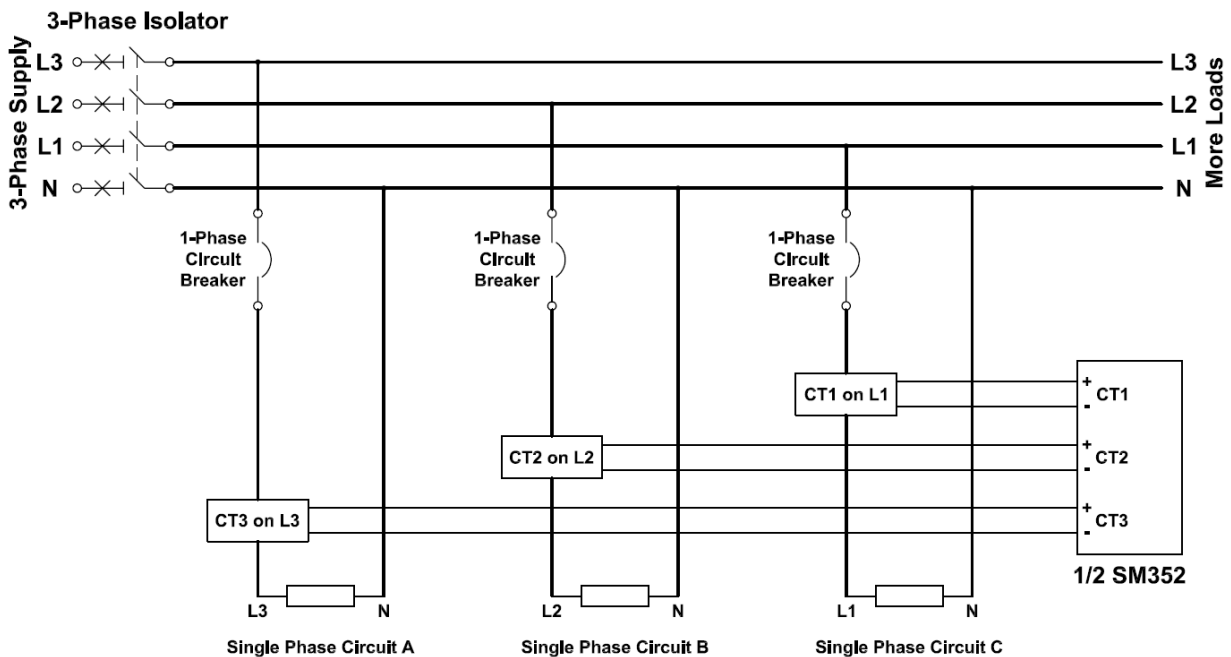

Figure 5-4 Measuring 3 x Single Phase Loads Using 1/2 SM352



6. Power Up/Configuration

6.1. Powering up a *multicube* System

Before supplying power to the **multicube** system check all wiring, ensure the unit is securely mounted to a stable surface and clean up all debris, scraps of wire etc.

When power is applied to a **multicube** a system hardware check is carried out to determine which modules are connected and how these are configured. The power up screen displays the progress of this system configuration check.



Symbol	Meaning
	Module Position Empty
	Module not recognised by the system
	Recognised Module

Other information on the Power up screen, such as software version, may be required when contacting the manufacturer for technical support.

The Error LED may also illuminate for a short period during power up.

multicube

Modular Metering System - Configuration

6.2. Configuring a New Multicube System

All new **multicube** systems are factory configured and calibrated with at least the following components:

1. A Master Display unit
2. At least 1 Metering Module (eg **SM352** dual meter).

Default settings are provided which can be user configured during commissioning to suit the site to be monitored and host communication requirements. Default settings are as follows:

Setting	Default Setting
System - Name	"ND Multicube"
System – Volts Demand Period	30 minutes
System – Amps Demand Period	30 minutes
System – Power Demand Period	30 minutes
System – Logging (optional)	Disabled
System – RS485 (optional)	Modbus ID = 1 Baud = 9600 Parity = None
Meters – Load Name	"< Meter N >"
Meters – Communications	Load Modbus IDs = 2,3,4 From left to right, top to bottom
Meters – CT Type	Split CT 150A-0.33V
Meters – Load Type	3-Phase
Meters-Autorotate	Enabled

On power up, **multicube** systems recognise and accept their factory configured modules. Changes to the system hardware configuration may be made in the field such as adding/removing modules providing the original minimum component hardware configuration (above) is maintained.

6.3. Configuring a Modified Multicube System



Hardware changes made to a **multicube** system such as adding/removing modules are detected during the power up and may require action by the user to confirm these changes before the system accepts the new configuration.

6.3.1. After Adding New Modules

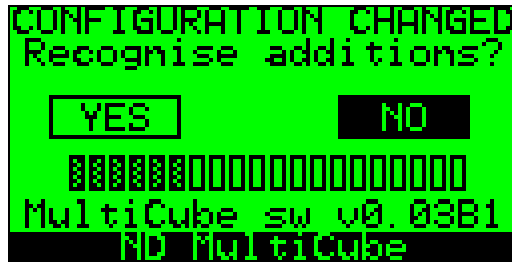
If one or more new modules are detected during power up checks, the following screen is displayed:



The detected modules are recognised and shown in their position and the user is requested to accept these changes.

Use the   keys to select YES or NO and the  key to confirm the selection.

NOTE: The “Configuration Changed” screen times out after approximately 20 seconds.

6.3.1.1. Selecting NO (default)

If **NO** is selected (or the screen is allowed to timeout with **YES** or **NO** selected):

- The system continues to operate unchanged with previously configured and accepted modules.
- New modules are skipped when selecting loads in normal operation.
- Existing communications IDs (e.g. Modbus) remain unchanged regardless of physical position in the **multicube** system.
- New modules are not available on the communications (e.g. Modbus) system.

6.3.1.2. Selecting YES

If **YES** is selected.

- New modules are added to the **multicube** system and made available for display.
- Existing communications IDs (e.g. Modbus) remain unchanged regardless of physical position in the **multicube** system.
- New modules are available on the communications (e.g. Modbus) system with consecutive IDs that start at the previous largest ID+1.

NOTE: In order for the data logger (optional) to record data from new module(s), the user must STOP the current LOGGING SESSION and start a new one.

6.3.2. After Removing Modules

If power up checks determine that one or more modules have been removed, the following screen is displayed:

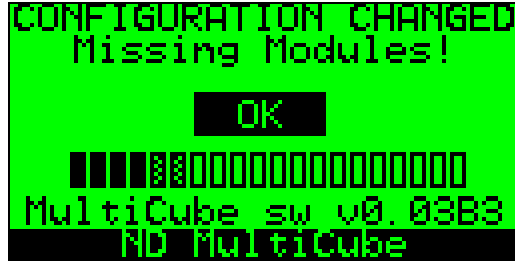

NOTE: The "Configuration Changed" screen times out after approximately 20 seconds.

Press  key to remove the message or wait for the screen to timeout.

- The system continues to operate with the configuration of the remaining modules unchanged.
- Communications IDs (e.g. Modbus) of the remaining modules are unchanged regardless of their physical position in the **multicube** system.
- Removed modules may return invalid data on the communications (e.g. Modbus) system.
- Logged data for removed modules is not available.



If a module is removed permanently it is advised that the system is reconfigured using the "Renumber Slaves" the option in the *Setup - Advanced* menu. This removes all trace of the modules and renumbers the other modules to fill the gap.

6.3.3. After Replacing Modules

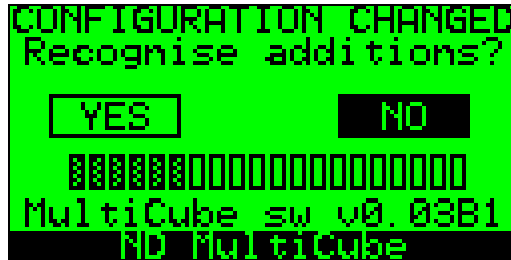
If a module is replaced by an unconfigured module of the same type (for example when replacing a faulty module) the user is given the choice of configuring the replacement module with the same user settings as the module being removed.



The detected module(s) are recognised and shown in their position and the user is requested to accept the changes.

Use the   keys to select YES or NO and the  key to confirm the selection.

NOTE: The “Configuration Changed” screen times out after approximately 20 seconds.

6.3.3.1. Selecting NO (default)

If **NO** is selected (or the screen is allowed to timeout with **YES** or **NO** selected):

- The system continues to operate unchanged with previously configured and accepted modules.
- Replacement modules are skipped when selecting loads in normal operation.
- Existing communications IDs (e.g. Modbus) remain unchanged regardless of physical position in the **multicube** system.
- New modules are not available on the communications (e.g. Modbus) system.
- Removed modules are not available on the communications (e.g. Modbus) system.
- Logged data for removed modules is not available.

6.3.3.2. Selecting YES

If **YES** is selected.

- New modules are added to the **multicube** system, in place of removed modules and are made available for display.
- New modules which replace removed modules are automatically configured with the settings of the removed modules.
- Existing communication IDs (e.g. Modbus) remain unchanged providing the number of modules in the **multicube** system is not changed.
- Logged data for replaced modules is not lost.

multicube

Modular Metering System - Configuration

6.4. Powering-Up a Configured Multicube System



- Switch on the auxiliary supply to the unit

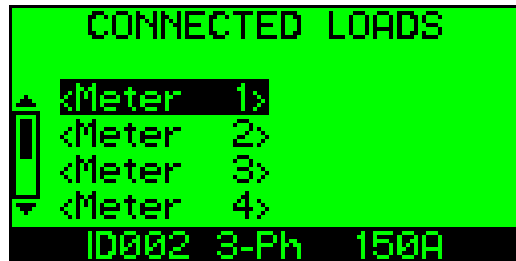

The power up screen details the software version for the Master Display Unit and a progress bar shows connection of each Sub Module as it is automatically identified. This screen is displayed for approximately 10 seconds.

- **Connected Loads List**



Use the   keys to select a load from the list and press  to show the default measurement page for the highlighted load.

The bottom line (Highlighted Text) gives details of the selected module:

- **The Communications ID (eg Modbus ID).**
- **The selected channel (“Ph1”-“Ph3” or “3-Ph” for 3-Phase Loads)**
- **The Current Transducer nominal primary current.**

Un-commissioned systems will display default names and all meters will be set to measure 3-Phase loads. It may be useful to refer back to this **Connected Loads List** after commissioning to check the system configuration.

multicube

Modular Metering System - Configuration

6.4.1. System Information Pages

The system information page provides the user with details of the connected modules at any time during operation of the multicube system.

Select System Info
From the
CONNECTED LOADS



View the
System Information page



Select to View
Master/Module(s) Information

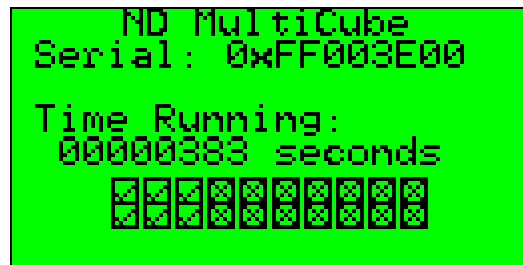

Return to Module List



Module present and configured



Module not present



Module present but not yet configured

6.4.1.1. Master Information

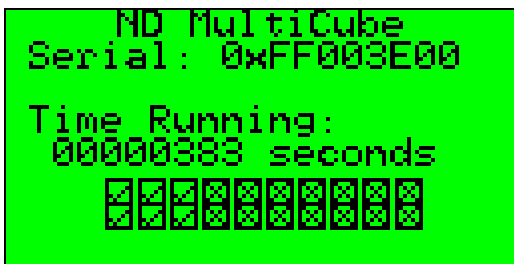

User Name for the Master Display Unit
Serial Number for the Master Display Unit

Run time (since last power up)

Module status by position

6.4.1.2. Selected Slave Information (SM352)



Selected Module: Serial Number Firmware Version
Voltage: System, Nominal, Calibration Adjust
Current Transformer: Primary Secondary Phase Multiplier
Current Demand Periods (seconds/10)
Power Demand Periods (seconds/10)

Module Status – Selected Module Highlighted

Module Position (Type) Comms ID Meter Type

multicube

Modular Metering System - Configuration

- Default Measurement Page

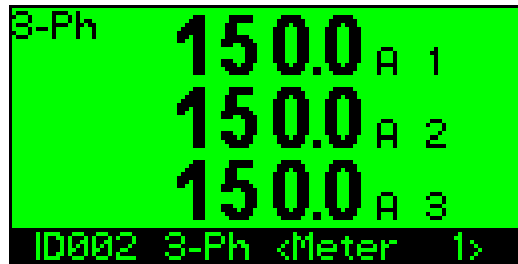

This page shows measured values from the selected meter/load. This data is meaningless for an unconfigured **multicube** system as the programmed Current Transducers may not match the physical devices fitted.

The bottom line (Highlighted Text) shows details of the selected load as:

- The Communications ID (eg Modbus ID).
- The selected channel (“Ph1”-“Ph3” or “3-Ph” for 3-Phase Loads)
- The programmed Load Name (Up to 14 Characters)

An LED is illuminated on the selected Module to indicate which phase is displayed on the LCD.

Display Current parameters for the selected load.



Display Voltage parameters for the selected load.



Display Power parameters for the selected load.



Display Energy parameters for the selected load.



Select a load to be displayed (The LED associated with the selected load is illuminated)



*Press/Release to show next page
Press/Hold for fast scroll*

*Press/Release to select next Load
Press/Hold to select from a Load List*

Note: A different set of parameter display pages is available for single phase and 3-phase loads. For a list of available pages refer to Section 7.3.

Modular Metering System - Configuration

- **Password Entry Screens**

Some programming features may be protected by a user password. Two levels of password are supported allowing more advanced features to be protected for use only by authorised users.

Move to:

Next / Previous Digit
ESC / OK

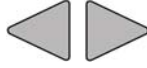

Increment / Decrement Digit



Confirm:

OK – Issue the Password
ESC – Return to Prev Screen



NOTE: If a password of 0000 is set, the password entry screen is not shown and immediate access is granted.

If an incorrect password is entered the user is returned to the previous screen.

The factory Set Default Passwords are:

Level 1: 0 0 0 0

Level 2: 1 1 1 1

To change the user passwords refer to Section **XXXX**

multicube

Modular Metering System - Configuration

6.5. System Name

Each **multicube** system can be given a user defined '**Name**' so it may be individually identified. Names are up to 14 Alpha-Numeric characters and are entered in the **Setup Main** page as follows:

Enter Setup Mode



Hold Setup Keys for 5 Seconds

Select System Name from the **SETUP MAIN** Menu

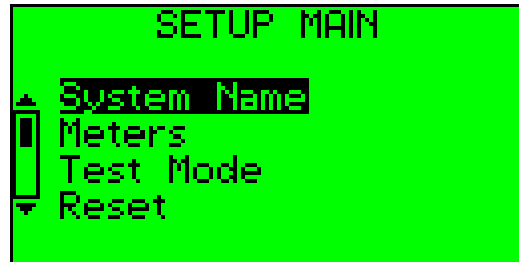

View/Edit the System Name



Switch between **Character Entry Mode** and **Function Key Mode**



Function Key Mode

< - Previous Character
- > Next Character
a/A Lower/Upper Case
OK Accept New Name
ESC Abandon Changes

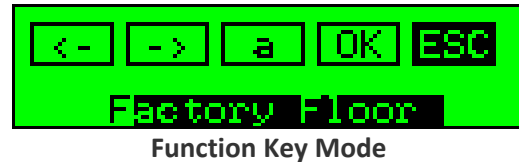
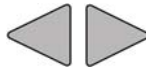

Character Entry Mode

Select Character

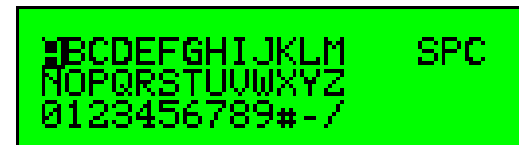
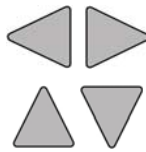

Enter Selected Character in Current position.



Character Entry Mode

multicube

Modular Metering System - Configuration

6.6. Setup Each Electricity Meter Module (SM352)

Each Electricity Metering Module **SM352** contains two complete 3-phase electricity meters, each of which may be optionally configured to monitor 3 single-phase loads.

To configure a Meter Module:

- Select the Current Transducer Type matching those connected. Suitable CTs are supplied by the manufacturer and are labelled with the type.
- Configure the meter to measure a 3-phase load or 3 individual single-phase loads.
- Set Autorotate Mode On/Off.
- Give each load a useful name, to be displayed on the LCD and available via Comms.

NOTE: The 3 inputs of each 1/2 SM352 must be connected using the same type of CT.

6.6.1. Select a Current Transducer Type

Enter Setup Mode



Hold Setup Keys for 5 Seconds

Select Meters
From the Main Menu

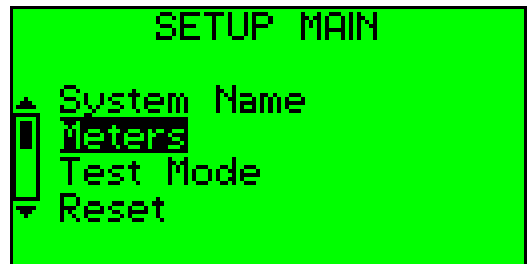

View/Edit the Meter Setup



Select a Meter Module

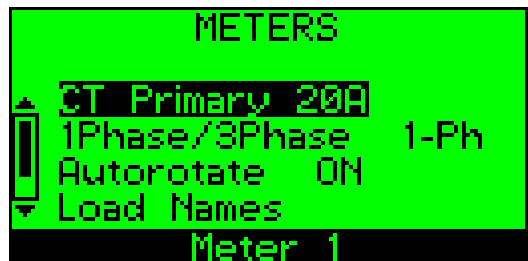

Show CT List



Match the CTs Connected to this
Meter to a type in the List

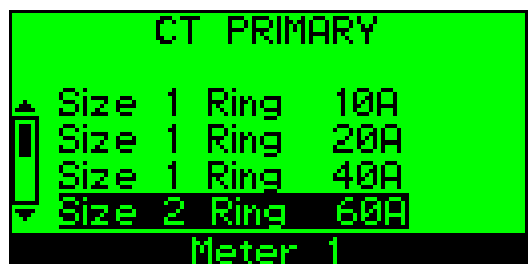

Accept the CT Selection



multicube

Modular Metering System - Configuration

6.6.1.1. If User Spec CT is Selected

It is possible to enter a user CT Specification for each Meter in place of selecting standard devices from the list. This is an advanced option, which is only required in exceptional circumstances and should not be used without technical support. A **Level 2 Password** is required when selecting a **User Spec CT**. This can be entered as described above.

NOTE: The SM352 is designed to compensate for small phase errors produced by each standard current transducer on the list. When a User Spec CT is used with the SM352 this phase error should match the specification of the device used or potential measurement errors will occur at low power factors. Current Transducers/Transformers not approved for use with the SM352 may permanently damage the Meter inputs.

6.6.1.2. Enter a User Defined CT Specification

Select *User Spec CT*
From the *CT PRIMARY* list



View/Edit the User Spec CT

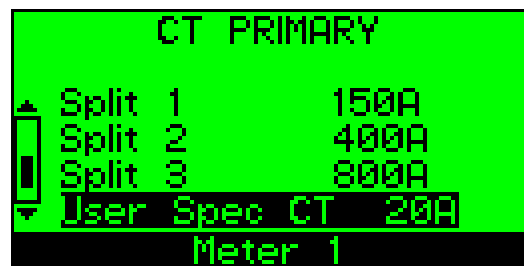

Select The User Primary



Edit the Primary Current

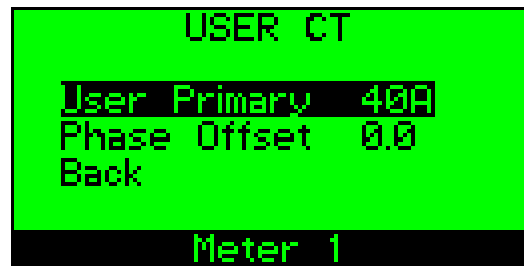

Move to:
Next / Previous Digit
ESC / OK

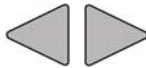

Increment / Decrement Digit





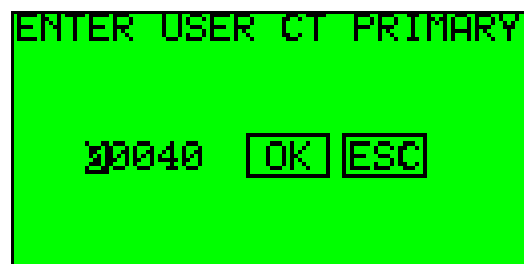



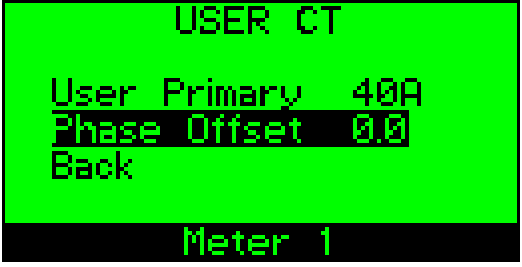

Confirm:
OK – Issue the Password
ESC – Return to Prev Screen

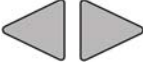
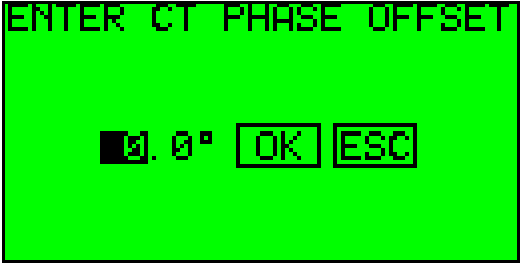

multicube

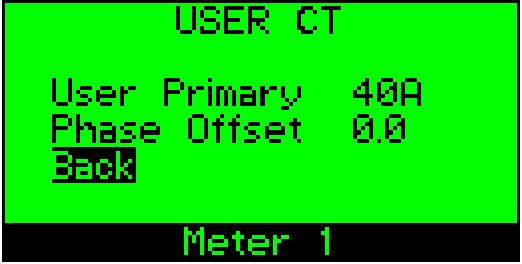
Modular Metering System - Configuration

Select Phase Offset		
Edit the Primary Current		
Move to: Next / Previous Digit ESC / OK		
Increment / Decrement Digit		
Confirm: OK – Issue the Password ESC – Return to Prev Screen		
Select Back when User CT is defined.		
Accept the User CT Specification for the selected Meter.		

6.6.2. Custom CT Selection

A single **Custom Current Transducer Specification** may be defined, by an authorised user, and will then be available for selection from the Standard CT list.

A **Custom Current Transducer Specification** is defined by setting its CT Primary, and Phase Offset.

NOTE: Current Transducers/Transformers not approved for use with the SM352 may permanently damage the Meter inputs.

NOTE: The Custom CT specification is entered in the Advanced Settings Menu, which requires a Level 2 Password as, described above.

multicube

Modular Metering System - Configuration

6.6.3. Set the Meter Module to Measure a 3-Phase or 3 Single Phase Loads

Select 1Phase/3Phase

The current mode is shown:
3-Ph or 1-Ph



Toggle Meter Types

3-Ph – 3 Phase Load

1-Ph – 3 x Single Phase

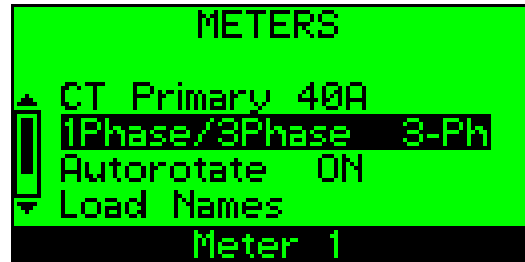

6.6.4. Set Autorotate Mode ON/OFF

When the **Autorotate** function is **ON** (default) the orientation of each current transducer on its associated conductor is irrelevant. If a CT is placed the wrong way round then the **Autorotate** system will automatically compensate for this.

If measurement of **Export power/energy** is required to then it is necessary to switch **Autorotate OFF** and ensure the CTs are mounted the correct way round on the conductors.

Select **Autorotate**

The current mode is shown:
ON or **OFF**



Toggle **Autorotate**

ON - Normal Operation

OFF – Import/Export Power

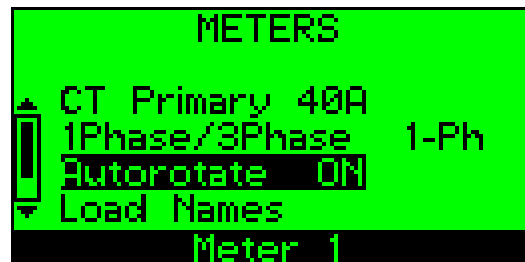

multicube

Modular Metering System - Configuration

6.6.5. Set a Name For Each Meter

An alphanumeric name may be associated with each load so that it may be identified on the LCD and over the Modbus or other communications link. Each measured load requires a name, so a meter measuring a single 3-phase load requires a single name while a 3 x Single Phase meter requires three names.

Select Load Names



View/Edit the Load Name(s)

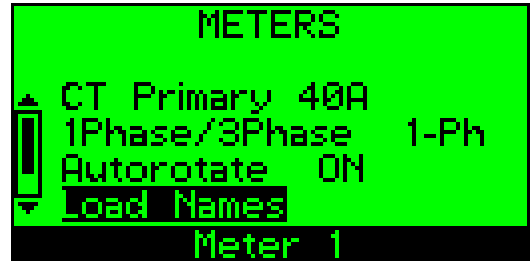

Select The Meter to Edit



Note:

3-Phase Meters Require 1 Name.
1-Phase Meters Require 3 Names



3-Phase Load (Single Name)

Select a Load Name



Edit the Load Name

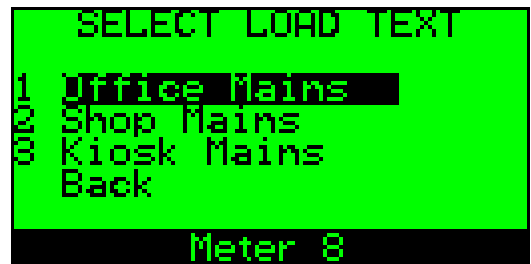

3 x Single Phase Loads (3 Names)

multicube

Modular Metering System - Configuration

Switch Between:
Character Entry Mode
and
Function Key Mode



Function Key Mode

< - Previous Character
- > Next Character
a/A Lower/Upper Case
OK Accept New Name
ESC Abandon Changes

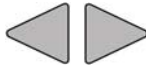

Character Entry Mode

Select Character

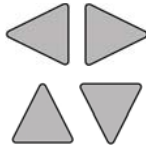

Enter Selected Character in
Current position.

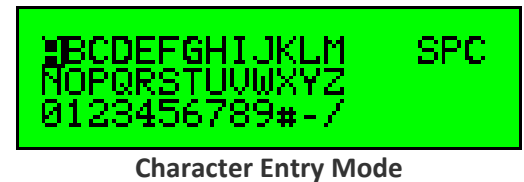

6.6.6. Repeat Meter Setup for All Meter Modules

Repeat the programming sequence for all attached loads as described above.

Select *Back* when Meter
Programming is complete



Return to *SETUP* Menu

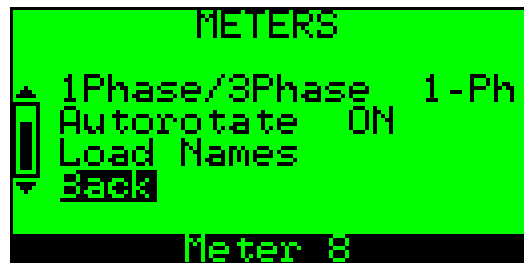

6.7. Test Mode

A series of load tests may be quickly performed to check the installation and validate connections. To test a load:

- Ensure the load to be tested is ON and in a normal operating mode.
- For import/export meter types ensure the load is importing current
- Step through the load tests
- Isolate the system and correct installation errors where required.

NOTE: Very low Power Factor measurements (<0.55) are used to indicate installation errors. If the load measured actually produces such a low PF then test results may be invalid.

NOTE: If more than one error occurs simultaneously the first error in the list below will be shown until the error has been corrected.

6.7.1. Installation Errors:



No Error Detected

- The Current Transformer appears to be on the correct phase (Power Factor > 0.55).
- Sufficient load current is flowing for a valid test.
- The phase voltage is healthy.



Insufficient Phase Voltage to carry out a Valid Test

- Check that the voltage wiring and ensure circuit breakers are ok.



Insufficient Load Current to carry out a Valid Test

- Check that the load is running before carrying out the test.



Current Transformer Mounted on the Wrong Phase Cable

- This results in low power factor and kW measurements.
- Check the wiring and move the CTs to the correct phase.



Current Transformer Reversed on its Cable (Auto CT reverse activated)

- This occurs when the CT is reversed on its cable and indicates that the meter is automatically correcting for this error.
- There is no need to rotate the CT in this case this symbol is shown purely for information.



Current Transformer Reversed on its Cable (Import/export meter)

- This result is only valid for import/export meter types.
- This results in negative kW measurements.
- Check the wiring and rotate the CT on its phase cable.

multicube

Modular Metering System - Configuration

Enter Setup Mode



Hold Setup Keys for 5 Seconds

Select Test Mode from the Main Menu



Enter Test Mode

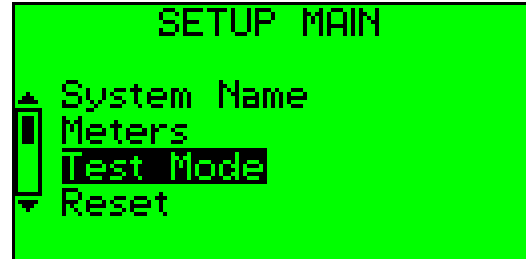

Select Connection Test



Enter Connection Test Mode

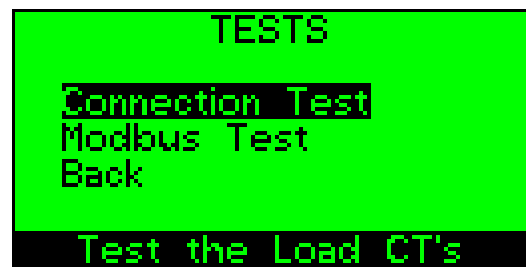

Connection Test - Power Factor

Select Meter to Test



Next / Previous Test



Exit Connection Test Mode

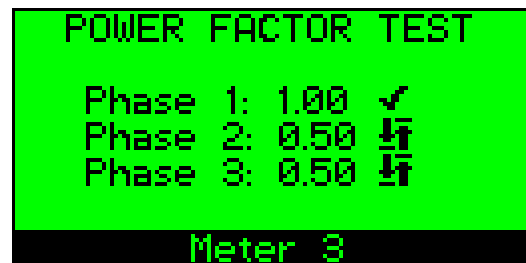

Connection Test – Amps

Select Meter to Test



Next / Previous Test



Exit Test Mode

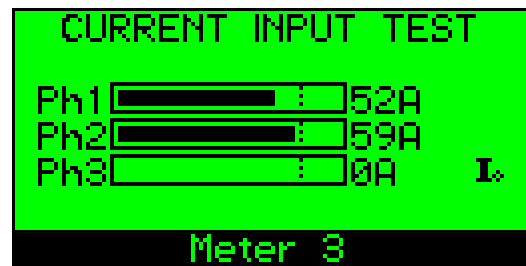

multicube

Modular Metering System - Configuration

Connection Test – Volts

Select Load to Test



Next / Previous Test



Exit Test Mode

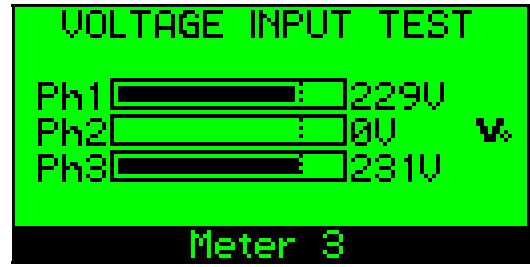

Connection Test – CT Rotation

Select Load to Test



Next / Previous Test



Exit Test Mode

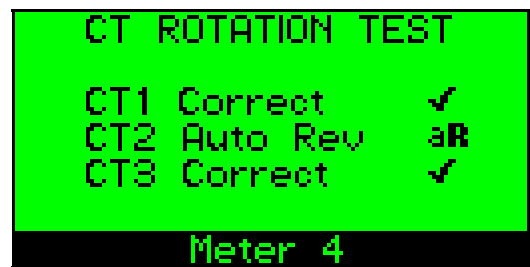

multicube

Modular Metering System - Configuration

6.8. Reset Saved Data

Various stored parameters may be reset to zero using the programming menus.

- “All Loads” – Reset all meter modules simultaneously
- “All Demands” – Reset Volts, Amps and Power Demands simultaneously
- “All Energy” – Reset all energy registers simultaneously

Enter Setup Mode



Hold Setup Keys for 5 Seconds

Select Reset from the
SETUP MAIN Menu

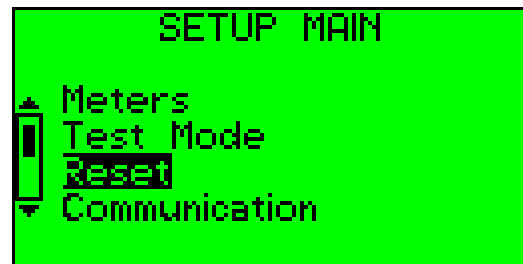

Enter the Reset Menu *



Select a single load or All Loads
to reset.



Select One or More Parameters
to Reset



Toggle Between:

✓ Reset Stored Value

✗ Don't Reset Stored Value

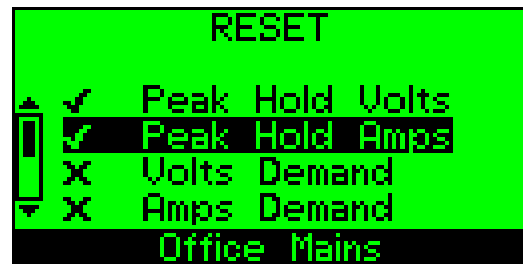

Select Next from the *RESET*
Menu



Proceed With Reset **

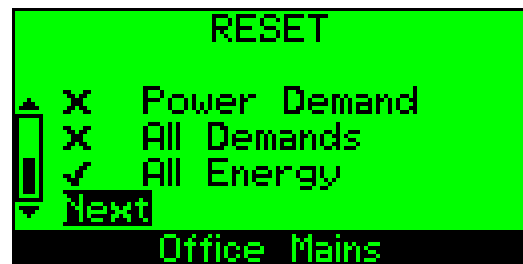

WARNING MESSAGE

CONFIRM: Perform Resets
CANCEL: Exit Without Reset

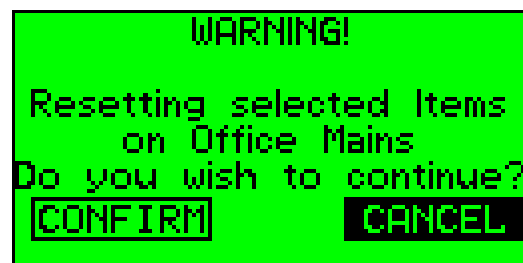
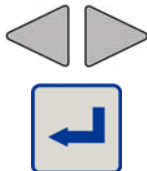

* If passwords are enabled enter your password as described above.

** Exit to main menu if no parameters are selected

multicube

Modular Metering System - Configuration

6.9. Setup Modbus Communications (Optional)

Each **multicube** fitted with the Modbus communications option is assigned a range of unique IDs. Further information on this is available in the *Multicube System - Communications Manual*.

- The user assigns a unique ID for each **multicube** in the Modbus network leaving gaps for the Master Display Unit to automatically assign a further set of consecutive IDs (2 for each module).
- The user selects a baud rate to suit the Modbus system setting.
- The user set the Parity to suit the Modbus system setting.

Note: Parity is set to NONE for the majority of Modbus systems.

Enter The *SETUP MAIN* Menu



Hold Setup Keys for 5 Seconds

Select *Communication* from the *SETUP MAIN* menu



Enter the Communication Setup Menu

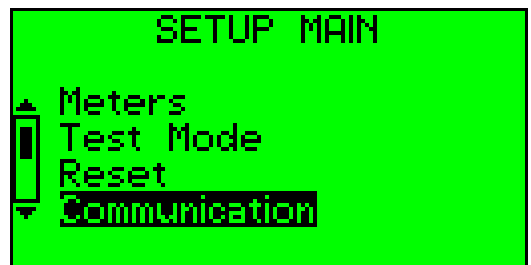

Set The Modbus ID

Select Modbus ID from the menu



Enter to change the value



Select a *Digit*, *ESC* or *OK*

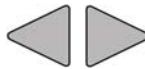

Change the Digit Value.



OK – Accept new value
ESC- Reject new value

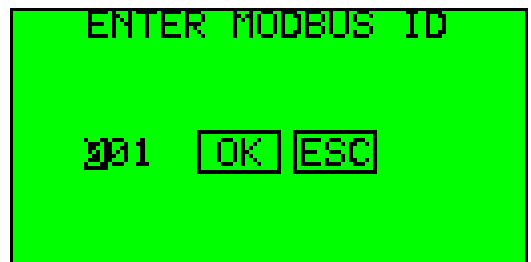

If the Modbus ID of the **multicube** Display Unit is changed the ID of each attached Slave unit is automatically updated starting from left to right (top to bottom) with the new ID +1, 2 etc.

multicube

Modular Metering System - Configuration

Set The Baud Rate

Select *Baud Rate* from the *Communication Menu*



```
COMMUNICATION
Modbus ID 1
Baud Rate 9600
Parity NONE
Back
9600-NO-1
```

Enter to Change the Value



Select the desired baud rate



```
BAUD RATE
4800
9600
14400
19200
Meter 1
```

Enter to accept the selection



Set The Parity

Select *Parity* from the menu.



```
COMMUNICATION
Modbus ID 1
Baud Rate 9600
Parity NONE
Back
9600-NO-1
```

Enter to Change the Value



Return To the *SETUP MAIN* Menu

Select *Back* from the menu



```
COMMUNICATION
Modbus ID 1
Baud Rate 9600
Parity NONE
Back
9600-NO-1
```

Exit to *SETUP MAIN* menu



multicube

Modular Metering System - Configuration

6.10. Test Modbus Communications (Optional)

The **multicube** system provides a facility for testing the RS485 communications network connection if the Modbus option is fitted.. This allows communications problems to be identified and remedied during commissioning.

Enter Setup Mode



Hold Setup Keys for 5 Seconds

Select *Test Mode*
from the *SETUP MAIN* menu

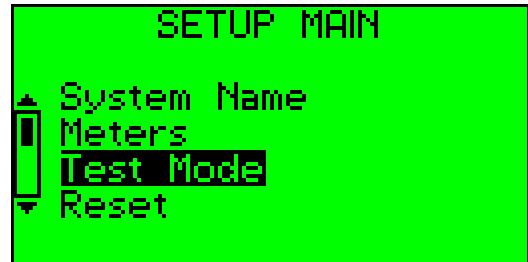

Enter Test Mode



Select
Modbus Test

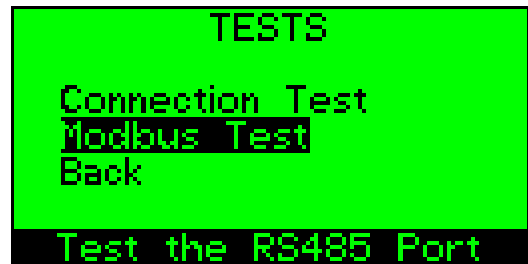

Enter Modbus Test Mode



Modbus Test Mode

Select:
RESET or EXIT Button

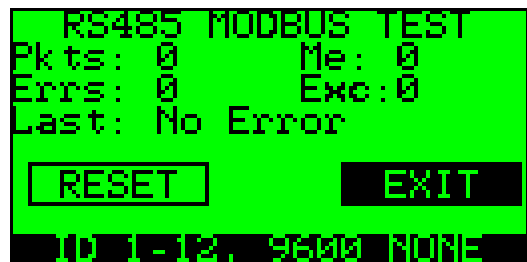
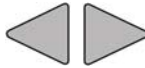

RESET – Reset Test Results
EXIT – Leave Modbus Test



Pkts:

Total Number of **RTU Framed Modbus Packets** detected on the RS485 Bus. These may be complete or incomplete packets. The structure/content of these packets is not examined in detail unless they are addressed to **ME**.

Me:

Total Number of **RTU Framed Modbus Packets** starting with **Any ID in My Range** including that of the **Display Unit** and all connected **Modules**. These may be complete or incomplete packets. The structure/content of these packets is examined in detail for errors.

Modular Metering System - Configuration

Errs:

This is a count of the Errors seen in RTU Framed Packets starting with Any ID in My Range including that of the Display Unit and all connected Modules. Exception errors are not counted here.

The following errors are identified:

- **Short Packet Length**
- **Long Packet Length**
- **Invalid Checksum**
- **Invalid Function Type**

Exc:

This is a count of the Exception Errors seen in RTU Framed Packets with Any ID in My Range including that of the Master Display Unit and all connected Modules.

Last:

This provides details of the last error to occur including *Exception Errors*

STATUS LINE:

The bottom line of the LCD (Highlighted) shows the current configuration of the Modbus Port.

- **ID 1-13** **The Range of IDs used by the system including the Display and Slave Modules**
- **9600** **The baud rate of the Master Display Unit.**
- **NONE** **Parity (NONE=No Parity, EVEN = Even Parity, ODD = Odd Parity)**

multicube

Modular Metering System - Configuration

6.11. Setup Logging (Optional)

The **multicube** system can be supplied with a built in data logger (Ref Section 8) which can store historical profiles of energy registers in flash memory that will be retained when power is removed from the system.

Enter Setup Mode



Hold Setup Keys for 5 Seconds

Select *Logging*
from the SETUP MAIN menu



Enter the Logging Menu

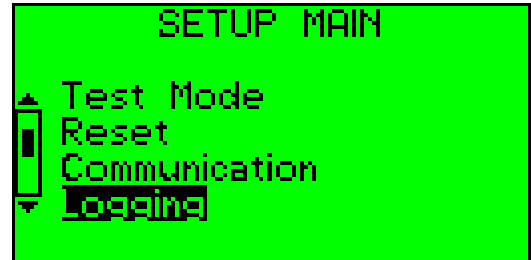

NOTE: New meters are supplied with logging STOPPED. Only when the logger is STOPPED can a new session can be setup or major changes made to the logger configuration. This prevents corruption of the data format in during an ongoing log session.

multicube

Modular Metering System - Configuration

6.11.1. Make Minor Real Time Clock Adjustments (Logger is Running)

It is possible to make minor adjustments to the real time clock while a log is in progress without stopping the logger. This may affect indexing of stored data on the day that the time is changed.

ADJUST TIME – WHILE LOGGER IS RUNNING

Select *Adjust Time*

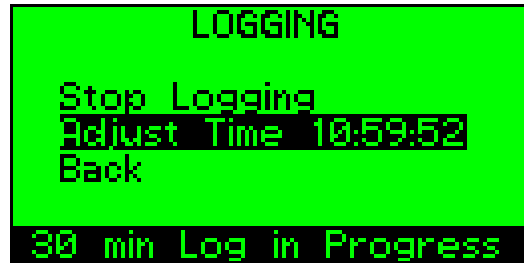

Change the time



Select CONFIRM or CANCEL

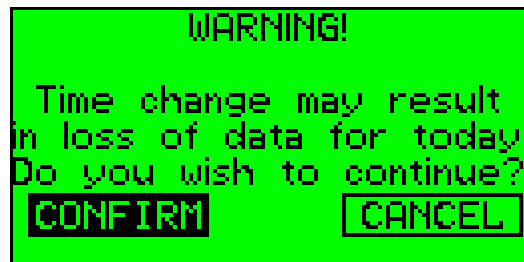
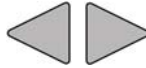

CONFIRM – Continue
CANCEL – Return To Menu



Select HOUR : MIN : SEC OK or ESC

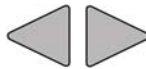

Change the Time Digits



OK – Set New Time
ESC – Escape / No Change



NOTE: Small time changes in the middle of a logging period will have least affect.







multicube

Modular Metering System - Configuration





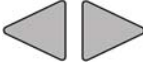
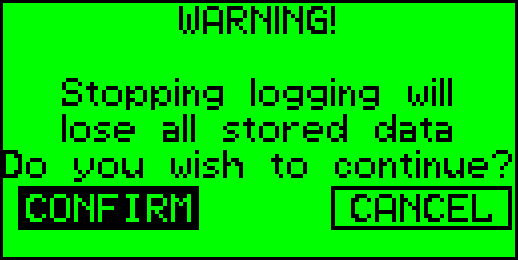

6.11.2. Setup a New Log Session (Logger Must be Stopped First)

- The user stops any ongoing data logging. Logged data will be lost when a new log is started so it is recommended that stored data be downloaded first.
- The user sets up a new logging session
- The user starts the new logging session
- Logging continues with the oldest data being replaced by the newest data when the logger is full (above).
- Stop The Logger

Stop Logging

Select Stop Logging		
Enter to STOP LOGGING!		
Select CONFIRM or CANCEL		
CONFIRM – STOP LOGGING CANCEL- Continue Logging		

Set A New Logging Period

Select <i>Period</i> from the menu		
Change the Period		
Select New Logging Period		
Accept New Period		

multicube

Modular Metering System - Configuration

Select Loads to Add to The Data Logger

Select *Logged Loads*
from the menu



Change the Period



Highlight a Load

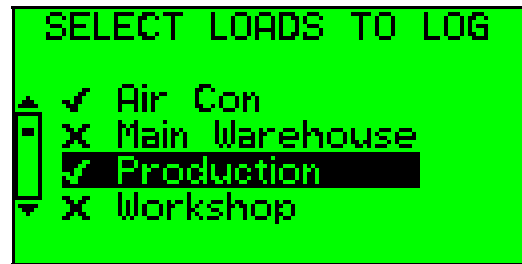

Toggle Between:

✓ Add Load to Logger

✗ Remove Load from Logger



When all Loads are selected
Go to *Back* (Last Item).



Exit to *LOGGING* menu.



multicube

Modular Metering System - Configuration

6.11.3. Setting Up The Real Time Clock/Calendar

A fully functional real time clock (RTC) is provided with the data logging option on the **multicube** system. The RTC is battery backed and will keep time in the event of power failure to the system. Setup of the RTC is only allowed when the Logger is STOPPED. Features of the RTC are described in detail in Section 8.

Set the Daylight Savings Period

With logging Stopped –
Select Date & Time



LOGGING SETUP LCD PAGE

Change the Time



Select Daylight Savings from the
SET DATE & TIME Menu

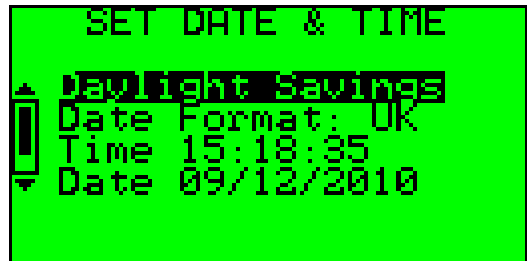

Change the Daylight Savings Settings



Select from:
DST Enabled, Start/End Date, Back

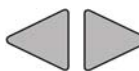

Edit the selection.



Select "Back" and Press to
Return to SET DATE & TIME Menu

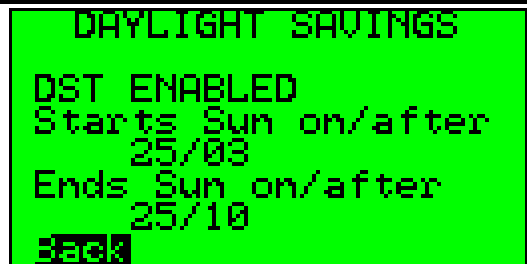

Note: Setting the dates for Daylight Savings does not affect the real time clock or the data logger operation. The daylight savings setting merely allows Day Data files, stored in the logger, to include a flag on days when daylight saving should be applied in external systems.

Set the Date Format

Select Date Format UK (US)



Toggle between UK and US Formats:
UK = DD/MM/YY
US = MM/DD/YY

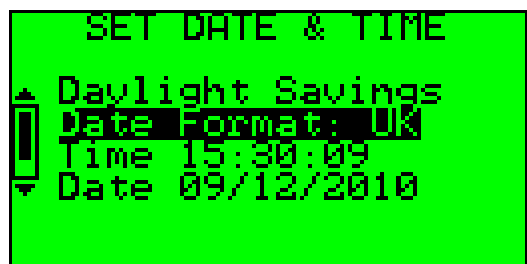

multicube

Modular Metering System - Configuration

Set the Current Time

Select Time *hh:mm:ss*



Change the Time

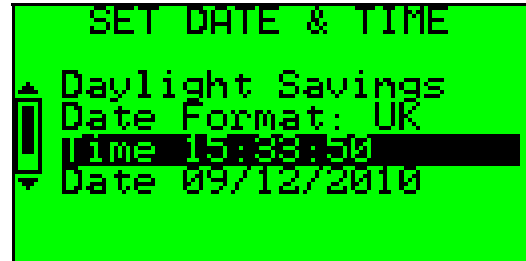

Select HOUR : MIN : SEC *OK* or *ESC*

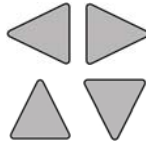

Change the Clock Digits

OK – Accept new time
ESC - Reject new time



Set the Real Time Clock (Date)

Select Date



Change the Calendar Date



UK: Select DAY / MONTH / YEAR
US: Select MONTH / DAY / YEAR
Select *OK* or *ESC*

Change the Calendar Digits



OK – Accept new Date
ESC - Reject new Date

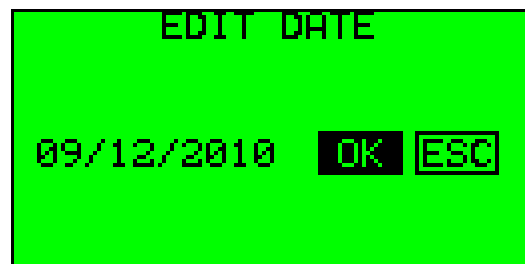

When the RTC Setup is complete:
Select *Back*



Return to *LOGGING* menu.

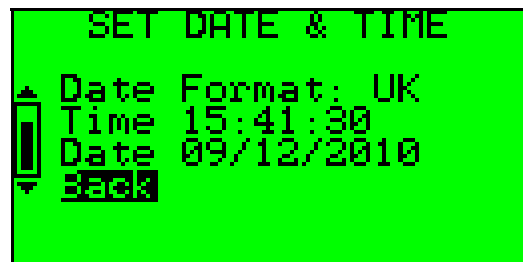

Modular Metering System - Configuration

6.11.4. Setting Up Energy Tariffs

multicube systems fitted with the Data Logging option allow energy accumulated during preset tariff periods to accumulate in up to 8 sets of Energy Tariff Registers. A full description of the Tariff register system is described in detail in Section 8.

Setup Energy Tariffs

With logging Stopped –
Select Tariffs



TARIFF MENU SELECTION LCD PAGE

Setup new Tariffs



Set the Tariff Costs

Select *Tariff Costs*



Change the Costs



Select Tariff N Menu Item



Select Tariff 1 – Tariff 8
(Current settings are shown)

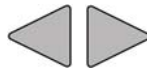

Select kWh Cost Menu Item



Change the kWh/kvarh Tariff N Cost



multicube

Modular Metering System - Configuration

6.11.4.1. Setting Tariff Costs

Each of the 8 Tariffs has a cost associated with it which is stored in the logger and may be used by external systems for bill validation calculations. The values set have no effect on other values stored in the **multicube** system but merely allow the user to maintain a local record of historic costs.

Select a Digit OK or ESC
OK – Accept new Tariff Cost
ESC - Reject new Tariff Cost

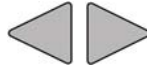

TARIFF 1 kwh ENTRY PAGE

Change The Digit Value



Select Back to return To Tariff Menu



Return to Main Tariff Menu



```
TARIFF COSTS
Tariff 1
kWh cost 0.34
kvarh cost 0.34
Back
```

multicube

Modular Metering System - Configuration

6.11.4.2. Defining Tariff Day Structures

Up to 8 Tariff Day Types may be defined for the **multicube** system as described in Section 8. A Day Type is defined by setting up to 8 consecutive periods which make up the day each of which may be associated with a selected Tariff. The values set have no effect on other values stored in the **multicube** system but merely allow the user to maintain a record of historic Tariff periods.

For example a Day Type may define:

Day Type 1			
Period	Start Time	End Time	Tariff
1	00:00	07:30	T3
2	07:30	15:30	T1
3	15:30	18:00	T6
4	18:00	00:00	T1

Day Types are setup graphically as:

Setting Up A Day Type (See Section 8)

Select Day Periods



Define/Change Day Periods



Select The Day Type 1-8 To Program

Select Day Type



Select Day Type 1 – Day Type 8
(Current settings are shown)

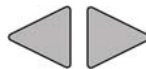

EDIT DAY TYPE
Day Type Number Selected

Define The Day Type Time Periods

Select The Time Period Graphic
for the selected Day Type



Select A Time Period to Adjust
(Selected period is highlighted)



EDIT DAY TYPE
Period Graph Selected

Adjust the Start/End Times for the
Selected period



multicube

Modular Metering System - Configuration

Associate a Tariff With Each Period

Select The Tariff Number



Select Each Time Period
(Selected period is highlighted)



EDIT DAY TYPE
Tariff Number Selected

Select a Tariff Number to Associate
With the selected Time Period.

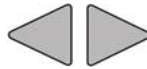

Return to Main Tariffs Menu

Select Back



EDIT DAY TYPE
Back Selected

Return to Main Tariffs Menu



6.11.4.3. Defining Tariff Week Structures

Up to 8 Tariff Week Types may be defined for the **multicube** system as described in Section 8. A Week Type is defined by selecting a Day Type for each day of the week allowing a comprehensive Tariff profile to be programmed for each week. The values set have no effect on other values stored in the **multicube** system but merely allow the user to maintain a record of historic Tariff periods.

For example a Week Type may define:

Week Type 1	
Day of Week	Selected Day Type
Monday	Day Type 1
Tuesday	Day Type 2
Wednesday	Day Type 2
Thursday	Day Type 2
Friday	Day Type 3
Saturday	Day Type 4
Sunday	Day Type 5

multicube

Modular Metering System - Configuration

Week Types are setup graphically as:

Setting Up A Week Type (See Section 8)

Select Week Types



Define/Change Day Periods



Select The Week Type 1-8 To Program

Select the Week Type Number



Select the Week Type to Edit
(Current Setting are Shown)

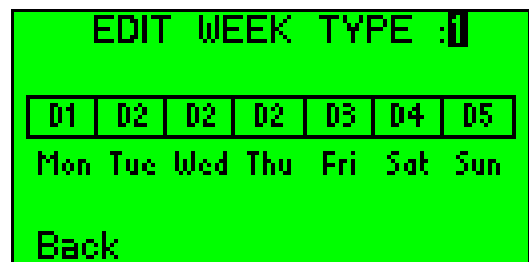
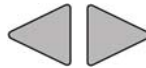

Program The Week Type

Select The Week Type Graphic



Select A Day of the week
(Selected day is highlighted)



Select a Day Type
For each day of the week

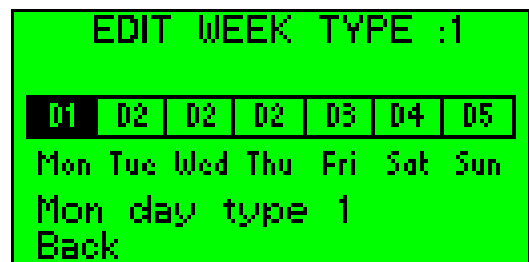
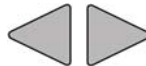

Return to Main Tariffs Menu

Select Back



Return to Main Tariffs Menu

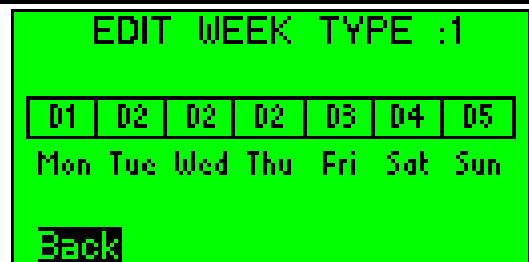

multicube

Modular Metering System - Configuration

6.11.4.4. Defining Tariff Seasons

Up to 8 Seasons per year may be defined for the **multicube** system as described in Section 8. Each season is defined as being a calendar period with a constant Week Type. For example we may have tariffs configured as Week Type 1 during the winter and Week Type 2 consistent throughout the summer. The values set have no effect on other values stored in the **multicube** system but merely allow the user to maintain a record of historic Tariff periods.

Seasons are setup graphically as:

Setting Up A Season (See Section 8)

Select Seasons 

Define/Change the Seasons 





```
TARIFFS
Tariff Costs
Day Periods
Week Types
Seasons
```

Define the Seasons Start/End Dates

Select the season Graphic. (Highlighted when selected) 

Select a Season to change. (Highlighted period in graphic) 

Edit the Start/End date. (Detailed below graphic) 





```
EDIT SEASON
J F M A M J J A S O N D
W1 W2 W3
Season 2 30/09-10/05
Week Type 3
Back
```

Define The Week Type For Each Season

Select the Week Type Number (Highlighted when Selected) 

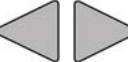
Select a Season (Highlighted period in graphic) 

Select a Week Type for the selected sseason. 



```
EDIT SEASON
J F M A M J J A S O N D
W1 W2 W3
Season 3 00/00-00/00
Week Type 1
Back
```

Return to Tariffs Menu

Select Back 

Return to Main Tariffs Menu 



```
EDIT SEASON
J F M A M J J A S O N D
W3 W2 W1
Season 2 09/09-21/04
Week Type 1
Back
```

multicube

Modular Metering System - Configuration

Return to Logger Menu

Select Back



Return to Logger Menu



Start the New Log Session

Select *Start Logging*



START Log Session



Select *CONFIRM* or *CANCEL*

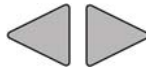

CONFIRM – Start Logging
CANCEL- Don't Start Logging



Complete Logger Setup

Select *Back*



Return to main Menu

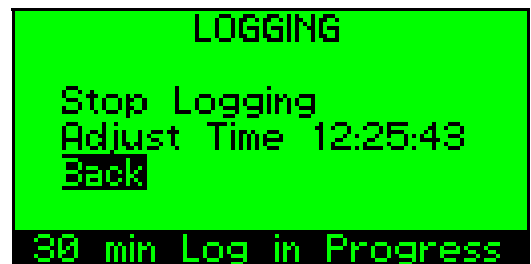

multicube

Modular Metering System - Configuration

6.11.5. Setup Demand Periods

Various average demand parameters are available in the **multicube** system. These are time-averaged values derived from standard instantaneous readings.

The time period over which each parameter is averaged can be programmed to suit end user applications. For example a 1-minute average Amps Demand measurement may be set to provide a current profile, which smoothes out small fluctuations caused by minor load switching.

Enter Setup Mode



Hold Setup Keys for 5 Seconds

Select Demand Periods from the **SETUP MAIN** menu

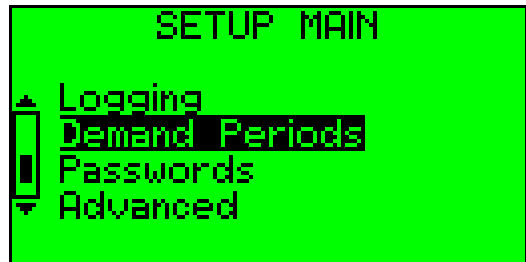

Enter the Demand Period Menu



Set a New Demand Period

Select the Demand Parameter to Change



Select The Load associated with the demand periods*



Set the Demand Period for the Selected Parameter.



Select the Demand Period



Change the Demand Period



Select another Demand Parameter to Change or



Select Back when all Periods are set on all loads

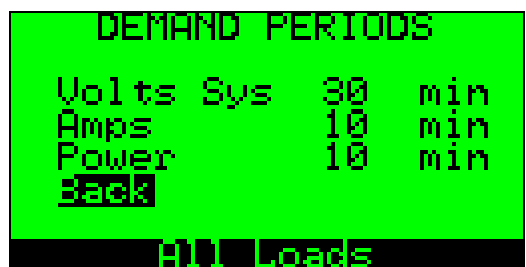

* A single Voltage Demand Period is set for the system as a whole and effects all loads.

multicube

Modular Metering System - Configuration

6.11.6. Setup Passwords to Restrict Keyboard Access

Some programming features may require a user password. Two levels of access may be set, each of which has a unique password. Only a user with access to Level-2 can modify passwords.

A Level-1 Password is required to access the Main Menu. Some Main Menu Items require the level-2 Password as detailed in the Table below.

If a password is set to 0000 then the associated password screens will not be shown.

Default factory password settings are Level-1 = 0000 and Level-2 = 1111. With these settings only level-2 screens, shown below, will require password entry.

Main Menu Item	Access Level
Reset	2
Logging	2
Passwords	2
Advanced	2

Enter Setup Mode



Hold Setup Keys for 5 Seconds

Select Passwords
from the *SETUP MAIN* menu



Set New Password(s)

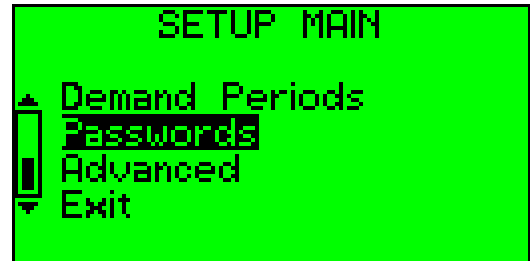

Enter Existing Level 2 Password

Move to:
Next / Previous Digit
ESC / OK



Increment / Decrement Digit



Confirm:
OK – Issue the Password
ESC – Return to Prev Screen

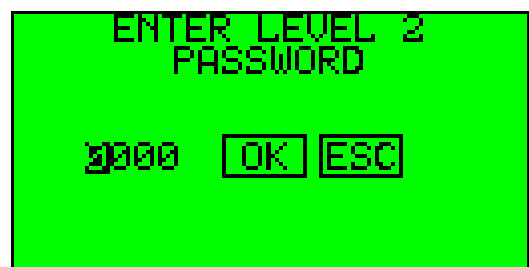

multicube

Modular Metering System - Configuration

Set new Password(s)

Select the Password

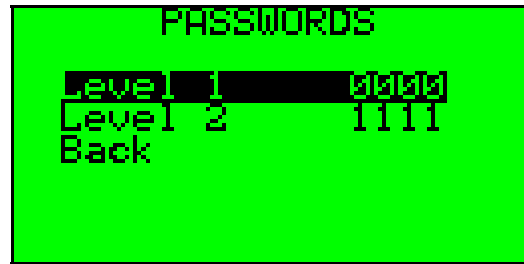

Change the Password



Edit The Existing Password

Move to:

Next / Previous Digit
ESC / OK

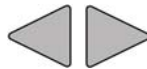

Increment / Decrement Digit



Confirm:

OK – Accept New Password
ESC – Return to Prev Screen



Select Back to Return to Main Menu



multicube

Modular Metering System - Configuration

6.11.7. Advanced Settings Menu

Advanced settings should only be used by authorised personnel with an in depth understanding of the **multicube** metering system and its application in its installed location.

6.11.7.1. Custom CT Primary

A user-defined Current Transducer can be configured which can then be selected from the list available for selection in *Meter Setup*. The **Custom CT** is defined by its Primary Current and a Phase Compensation values required to ensure accurate measurements at poor power factors.

WARNING: If incorrect parameters are set for the *Custom CT* this can lead to significant reading errors.

Enter Setup Mode



Hold Setup Keys for 5 Seconds

Select *Advanced*
from the *SETUP MAIN* menu

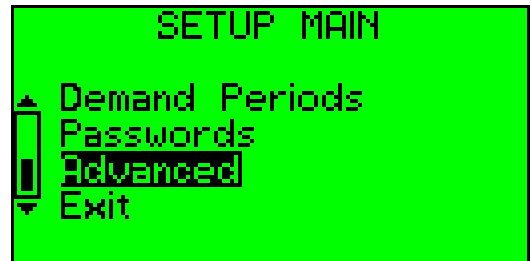

Enter the Advanced Settings Menu *



* A Level 2 Password may be required to gain access to the Advanced Menu. This is entered as described above.

Enter The Custom CT Primary Current

Select *Custom CT Primary*

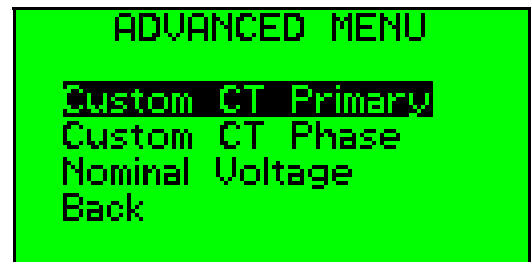

Change the Primary Current



Select:
Digit or *OK* or *ESC*

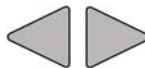

Change the Digit



OK – Accept new Value
ESC - Reject new Value



multicube

Modular Metering System - Configuration

Enter The Custom CT-Phase Offset

Select *Custom CT Phase*

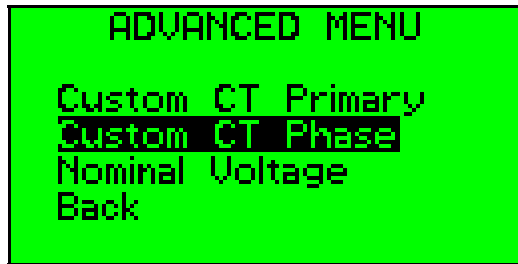

Change the Phase Angle



Select:
Digit or OK or ESC

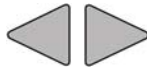

Change the Digit

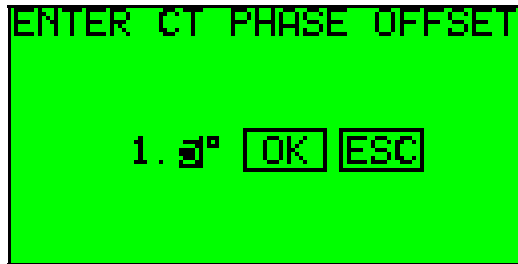

OK – Accept new Value
ESC - Reject new Value



multicube

Modular Metering System - Configuration

6.11.7.2. Advanced Settings Menu (Nominal Voltage)

The standard **multicube** voltage measurement inputs have a nominal rating:

230V (400V Line-Line)

Nominal Hardware Inputs

The inputs are suitable for measurements, including overload, in the range:

100V-277V (173V - 480V Line-Line)

Accurate Measurement Range

As standard the **multicube** is configured with a “Nominal Voltage” setting of:

230V (400V Line-Line)

Default Nominal Voltage Setting

Changing the Nominal Voltage setting to suit the actual voltage range of the power system in which the **multicube** is installed optimises the display resolution of power parameters. For example:

Nominal Volts = 120V

Optimal Setting for 120V / 208V System

Enter The Nominal System Voltage

Select Nominal Voltage
From the *Advanced Menu*



Change Nominal Voltage

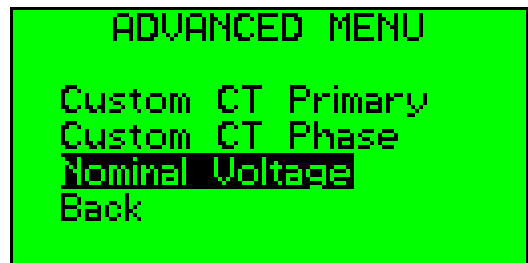

Select the Nominal Voltage
From the list



Accept the Nominal Voltage

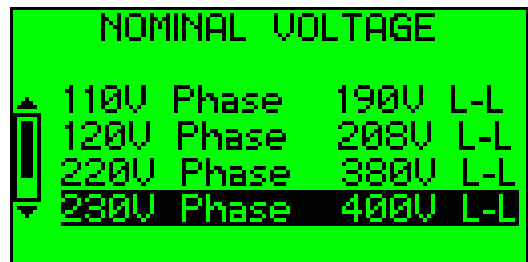

Return From Advanced Menu

Select another Advanced Setting to
Change or



Select *Exit*
to Return to Meter Display pages

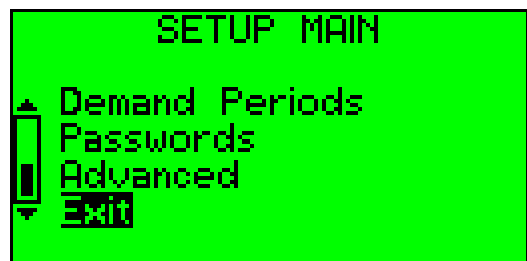

Modular Metering System - Operation

7. Meter Operation

Different measured loads are shown on the graphics LCD using the keypad on the **Master Display Unit**. Different sets of display pages are available for 1-Phase and 3-Phase loads.

7.1. Display Scaling

7.1.1. Voltage Scaling

The voltage display normally shows a 4 digit number scaled to 1 decimal place:

Examples: 230.0V, 400.0V

7.1.2. Current Scaling

The display resolution for all current (amps) parameters is set to provide 4 digits of resolution at the nominal CT Primary input.

CT Primary (Amps)	Current Display Resolution
5A to 8A	0.001 A
9A to 80A	0.01 A
81A to 800A	0.1A
801A to 8000A	1 A
> 8000A	0.01 kA

7.1.3. Power Scaling (Meters Configured for a Single 3-Phase Load)

CT Primary (Amps)	3-Phase Power Display Resolution	Single Phase Power Display Resolution
5A – 35A	0.01kW	0.001kW
36A to 350A	0.1kW	0.01kW
351A to 3500A	1kW	0.1kW
>3500A	0.01MW	1 kW

7.1.4. Power Scaling (Meters Configured for a 3 x Single Phase Loads)

CT Primary (Amps)	Single Phase Power Display Resolution
5A<11A	0.001kWh
11A to 100A	0.01kWh
101A to 1000A	0.1kWh
1001A to 10,000A	1kWh
> 10,000A	0.01MWh

7.1.5. Energy Scaling (Meters Configured for a Single 3-Phase Load)

CT Primary (Amps)	3 Phase Energy Display Resolution
< 5A	0.001kWh
5A – 35A	0.01kWh
36A to 350A	0.1kWh
351A to 3500A	1kWh
>3500A	0.01MWh

multicube

Modular Metering System - Operation

7.1.6. Energy Scaling (Meters Configured for 3 x Single Phase Loads)

<i>CT Primary (Amps)</i>	<i>Single Phase Energy Display Resolution</i>
<11A	0.001kWh
11A to 100A	0.01kWh
101A to 1000A	0.1kWh
1001A to 10,000A	1kWh
> 10,000A	0.01MWh

7.2. Sliding Window Demand

Average values of Volts, Amps kW, and kvar are calculated over a user programmable time period. The displays show the averages for the most recent time period ending at the time the display was last updated. The demand period is continuously updated as time progresses hence the term "**Sliding Window Demand**".

7.3. Load Display Menus

Each metered load is represented in display menus which are accessed using the user keypad on the *Master Display Unit*.

7.3.1. Capacitive and Inductive Loads

Measured parameters such as kvar and Power Factor are displayed with a symbol indicating the type of load:

Inductive Loads:  Capacitive Loads: 

7.3.2. 3-Phase Load Display Menus

3-Phase Current Display Menu



Select Current Pages



Select Load

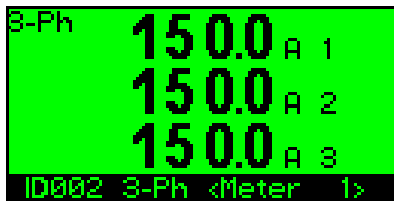

Instantaneous Phase Currents

Phase 1 Current
Phase 2 Current
Phase 3 Current

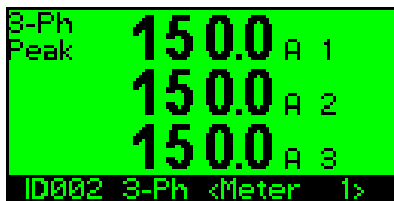

Peak Hold Phase Currents

Peak Hold Phase 1 Current
Peak Hold Phase 2 Current
Peak Hold Phase 3 Current

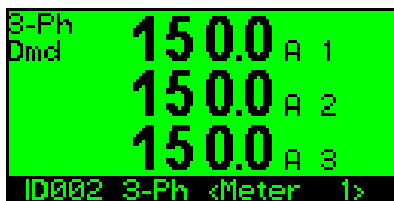

Current Demand (Sliding Window) Ref 7.2

Current Demand Phase 1
Current Demand Phase 2
Current Demand Phase 3

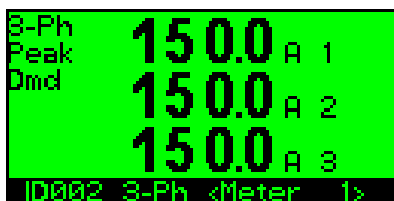

Peak Current Demand (Sliding Window) Ref 7.1

Peak Hold Current Demand Phase 1
Peak Hold Current Demand Phase 2
Peak Hold Current Demand Phase 3



Min Current Demand (Sliding Window) Ref 7.1

Minimum Hold Current Demand Phase 1
Minimum Hold Current Demand Phase 2
Minimum Hold Current Demand Phase 3



Current Total Harmonic Distortion (THD)

%THD Phase 1 Current
%THD Phase 2 Current
%THD Phase 3 Current

3-Phase Voltage Display Menu



Select Voltage Pages



Select Load



Instantaneous Phase to Neutral Voltages

Phase 1 to neutral volts
Phase 2 to neutral volts
Phase 3 to neutral volts

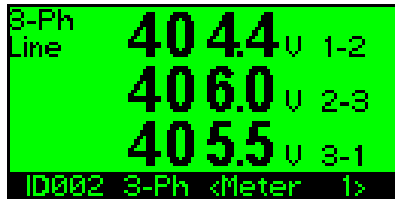

Instantaneous Line-Line Voltages

Line 1 – Line 2 volts
Line 2 – Line 3 volts
Line 3 – Line 1 volts

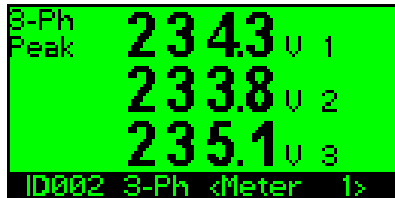

Peak Hold Phase to Neutral Voltages

Peak Hold Phase 1 Volts
Peak Hold Phase 2 Volts
Peak Hold Phase 3 Volts



Voltage Demand (Sliding Window) Ref 7.1

Voltage Demand Phase 1
Voltage Demand Phase 2
Voltage Demand Phase 3



Peak Voltage Demand (Sliding Window) Ref 7.1

Peak Hold Voltage Demand Phase 1
Peak Hold Voltage Demand Phase 2
Peak Hold Voltage Demand Phase 3



Min Voltage Demand (Sliding Window) Ref 7.1

Minimum Hold Voltage Demand Phase 1
Minimum Hold Voltage Demand Phase 2
Minimum Hold Voltage Demand Phase 3

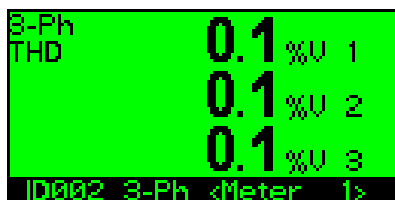

Voltage Total Harmonic

%THD Phase 1 Volts
%THD Phase 2 Volts
%THD Phase 3 Volts

3-Phase Power Display Menu



Select Power Pages



Select Load



Instantaneous System Power

System Real Power kW (P)
System Reactive kvar (Q)
System Power Factor (COS ϕ)



kW Demand (Sliding Window) Ref 7.1

kW Demand
Peak Hold kW Demand
Minimum Hold kW Demand

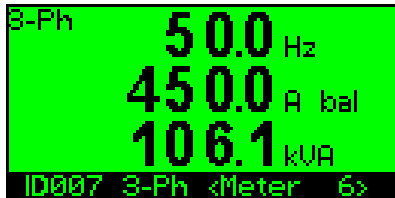

System Frequency, Neutral Current, kVA (S)

Frequency (Measured on Volts Ph1)
Neutral Current Ref **Error! Reference source not found.**
System Apparent Power kVA



Per Phase kW (P1-P3)

Phase 1 Real Power (kW)
Phase 2 Real Power (kW)
Phase 3 Real Power (kW)



Per Phase Reactive Power (kvar)

Phase 1 Reactive Power (Inductive shown)
Phase 2 Reactive Power (Inductive shown)
Phase 3 Reactive Power (Inductive shown)



Per Phase Power Factor (COS ϕ)

Phase 1 Power Factor (Capacitive shown)
Phase 2 Power Factor (Capacitive shown)
Phase 3 Power Factor (Capacitive shown)

3-Phase Energy Display Menu



Select Energy Pages



Select Load



Total System Import Energy

Real Energy kWh

Reactive Energy (kvarh)

Apparent Energy (kVAh)r

multicube

Modular Metering System - Operation

7.3.3. Single-Phase Meter Display Menus

NOTE: Each single-phase load is associated with a phase voltage determined by its position in a 3-Phase metering module. The phase voltages connected to the Master Display Unit are numbered Ph1 - Ph3 and this is indicated on the single-phase pages as "Ph1" - "Ph3".

Single-Phase Current Display Menu



Select Current Pages



Select Load

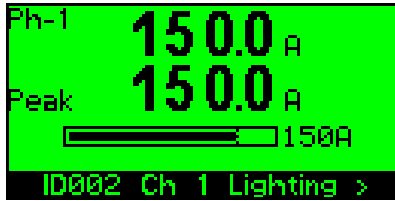

Instantaneous Phase Current

Phase Current

Peak Hold Phase Current

Bar Graph of Amps Scale = 0 - 120% CT Prim

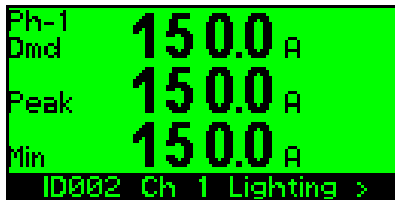

Current Demand (Sliding Window) Ref 7.1

Phase Current Demand

Peak Hold Phase Current Demand

Minimum Hold Phase Voltage Demand

Single-Phase Voltage Display Menu



Select Voltage Pages



Select Load

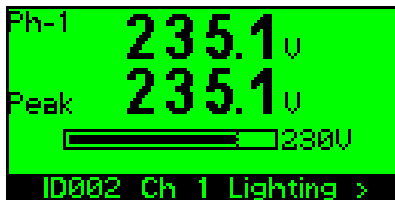

Instantaneous Phase to Neutral Voltage

Phase to Neutral Voltage

Peak Hold Phase Voltage

Bar Graph of Volts Scale = 0 - 120% Vnom



Voltage Demand (Sliding Window) Ref 7.1

Phase Voltage Demand

Peak Hold Phase Voltage Demand

Minimum Hold Phase Voltage Demand

multicube

Modular Metering System - Operation

Single-Phase Power Display Menu



Select Power Pages



Select Load



Instantaneous Phase Powers

- Single Phase Real Power (P)
- Single Phase Reactive Power (Q)
- Single Phase Power Factor (COSΦ)



Power Demand (Sliding Window) Ref 7.1

- Single Phase kW Demand
- Single Phase Peak Hold kW Demand
- Frequency (From Phase 1 volts)

Single-Phase Energy Display Menu



Select Energy Pages



Select Load



Single Phase Total Import Energy

- Single Phase Real Energy (kWh)
- Single Phase Reactive Energy (kvarh)

8. Data Logger/Tariffs (Optional)

8.1. Data Logger

The **multicube** system can be supplied with a richly featured energy data logger which stores historic **kWh** and **kvarh** profile data for up to 1000 days. The data logger also provides a store for up to 8 sets of accumulating **kWh** and **kvarh** Tariff Registers.

Once configured by the user the logger runs continuously, automatically replacing the earliest data with the newest.

Storage is in conveniently structured data files which hold 15, 20 or 30 minutes period energy register totals for each single day. Each **Day Data File** also holds summary information for that day allowing user software to review a comprehensive history.

The data in the logger is made available via the communications system (e.g. Modbus) as described in the appropriate **multicube System - Communications Manual**.

8.1.1. Storage Capacity

The logger can store up to 1000 days of energy profile data depending on the total number of loads being monitored. Each Sub-Metering Module configured as a 3-phase meter stores 1 Load Profiles and each Sub-Metering Module configured as 3 x 1 Phase stores 3 Load Profiles. It is the total number of Load Profiles stored which determines the logger capacity in days as:

Total Load Profiles Single + 3 Phase	Logger Capacity Number of Days
1-7	1,000
8-15	500
16-23	333
24-31	250
32-39	200
40-47	166
48-55	142
56-60	125

8.1.2. Daily Data Stored For Each Load

Data Description
Number of days since the logger was first started.
Calendar Date as Day - Month – Year
Day Data File Index. Incremented every time a <i>Day Data File</i> is stored. This may be used to speed up data searching.
Daylight Saving Flag
Total kWh registered up to the start of the logged day
Total kvarh registered up to the start of the logged day
kWh recorded in each sub period (15, 20 or 30 minutes) for 25 hours.
kvarh recorded in each sub period (15, 20 or 30 minutes) for 25 hours.
Start/End times for up to 8 Tariffs T1-T8. Saved every day so historic tariff changes can be recorded.
Associated values for up to 8 Tariffs T1-T8. Saved every day so historic tariff changes can be recorded. These are user set numbers 0-65000 which are stored along side the energy data but have no affect on it.
Total kWh and kvarh registered up to the start of the logged day measured during all T1 Tariff periods.
Total kWh and kvarh registered up to the start of the logged day measured during all T2 Tariff periods.
Total kWh and kvarh registered up to the start of the logged day measured during all T3 Tariff periods.
Total kWh and kvarh registered up to the start of the logged day measured during all T4 Tariff periods.
Total kWh and kvarh registered up to the start of the logged day measured during all T5 Tariff periods.
Total kWh and kvarh registered up to the start of the logged day measured during all T6 Tariff periods.
Total kWh and kvarh registered up to the start of the logged day measured during all T7 Tariff periods.
Total kWh and kvarh registered up to the start of the logged day measured during all T8 Tariff periods.

8.1.3. Logger Clock

The Logger clock should **ALWAYS** be set to local time **WITHOUT DAYLIGHT SAVING APPLIED**. This ensures that no data is lost on the days when Daylight Saving starts and ends. For example in the UK always set the Logger Clock to Greenwich Mean Time (GMT). This approach is the standard method used for data logging electricity values.

The logger clock is accurate to within 30 seconds per month. It is recommended that it is adjusted (via the communications interface or the control panel) regularly to ensure it is synchronised to other clocks in the system.

8.1.4. Daylight Saving

Although the data in the Logger is internally time-stamped without daylight saving time applied the **multicube** allows the user to record a flag in days when Daylight Saving is applied locally throughout the year. Storing this **Daylight Saving Flag** does not affect the data in the logger but merely provides a method by which stored data may be adjusted when it is read from the logger at a later date. In order to facilitate this retrospective shift of the time stamp, 25 hours of data are stored every day from 23:00 on the previous day to 24:00 on the day of the log.

8.1.5. When is Data Stored/Available

New **Day Data Files** are opened at 00:00h each day and available for reading from 01:30 that day. The totalised energy registers accumulated up to each logged day are stored at 00:00h and account for all time since the meter was first commissioned (or the values were manually reset).

8.1.6. Logger Status Information

A table of logger status information is available for reading using the communication interface which allows the user to keep track of its progress. The status information available includes:

- **Logger status (running or stopped)**
- **Number of loads being logged**
- **Maximum number of days which can be stored (dependant on number of loads)**
- **Memory status (full/overwriting or not full)**
- **Number of days since the logger was started**
- **Earliest day available for download**
- **Latest day available for download**

8.1.7. Starting/Stopping the Logger

Once the logger is setup it is recommended to leave it running allowing the oldest stored data to be overwritten by the latest. Regular downloads of the logger data reduces the download times and ensures the data is backed up.

If the logger configuration requires changing, for example to add/remove loads or to change the logging period, the logger must be stopped so that it may be reformatted. This is necessary to ensure that all Day Data Files in the logger are formatted equally. The following rules apply:

- **Stopping the logger prevents new data being added**
- **After the logger is stopped it is still possible to read the old logged data files**
- **The logger configuration can only be changed when the logger is stopped**
- **The logger date can only be set when the logger is stopped.**
- **Small adjustments to the logger clock are possible while the logger is running.**
- **Starting the logger always resets the file format using the latest configuration (even if it has not been changed) and old data is lost at this point.**

8.1.8. Power Failures

If the power supply to the **multicube** is removed for a period of time the following applies:

- **No measurement or logging can occur while the auxiliary power is removed.**
- **If power-up occurs in the same sub-period:**
Accumulation re-starts for that period on power-up resulting in a lower count at the end of this sub-period.
- **If power-up occurs in a later sub-period during the same day:**
Energy accumulated in the part completed power fail period is stored to the logger
Missing sub-periods are filled with energy values of zero
Accumulation re-starts part way through the power-up sub-period.
- **If power-up occurs on a later day:**
Energy accumulated in the part completed power fail period is stored to the logger.
Energy accumulated in periods to the end of the power-fail day is logged as zero.
Energy accumulated in periods on the power-up day before the power-up period is logged as zero.
Accumulation re-starts part way through the power-up sub-period on the power-up day.

8.2. Multiple Tariffs (Optional)

The kWh and kvarh energy measured during preset tariff periods is accumulated in up to 8 sets of energy registers. For example: The Sum of all kWh energy measured by a 3-Phase Slave 1 Meter during all Tariff 1 periods throughout the year are accumulated in Slave 1 Tariff 1 kWh. The Tariff registers option is only available as an add-on option to the data logger.

8.2.1. Tariff Values

Up to 8 Tariffs may be programmed, each defined by its number (T1-T8) and an associated value (0-65000). Tariff values are set by the user and recorded along with the energy profile in the Day Data Files so that historic changes to values such as cost may be conveniently recorded for future reference. The Tariff Values have no effect on the accumulating Tariff Registers.

8.2.2. Tariff Day Types

Up to 8 **Tariff Day Types** may be user defined which are split into a maximum of 8 time periods to suit a local energy tariff structure. A single Tariff is assigned, using its number, to each tariff period in each Tariff Day Type.

Example: To set a weekday tariff saved to Day Type 1 with:

A Day-time Tariff of T3 from 07:00h to 19:30h

A Night-time Tariff of T6 from 19:30 to 07:00

<i>Day Type 1</i>		
Day Period 1	00:00 – 07:00	Tariff = T6
Day Period 2	07:00 – 19:30	Tariff = T3
Day Period 3	19:30 – 24:00	Tariff = T6

Modular Metering System - Data Logger / Tariffs

8.2.3. Tariff Week Types

Up to 8 *Week Types* may be user defined each of which is made up of 7 *Day Types*.

Example: A summer week has different weekday and weekend tariffs as:

Monday to Friday

Day time from 07:00 to 19:30 = T3

Night time from 19:30 to 07:00 = T6

Saturday and Sunday

From Friday at 19:30 to Monday at 07:00 = T2

<i>Monday</i> <i>Day Type 1</i>		
Day Period 1	00:00 – 07:00	Tariff = T2
Day Period 2	07:00 – 19:30	Tariff = T3
Day Period 3	19:30 – 24:00	Tariff = T6

<i>Tuesday – Thursday</i> <i>Day Type 2</i>		
Day Period 1	00:00 – 07:00	Tariff = T6
Day Period 2	07:00 – 19:30	Tariff = T3
Day Period 3	19:30 – 24:00	Tariff = T6

<i>Friday</i> <i>Day Type 3</i>		
Day Period 1	00:00 – 07:00	Tariff = T6
Day Period 2	07:00 – 19:30	Tariff = T3
Day Period 3	19:30 – 24:00	Tariff = T2

<i>Saturday – Sunday</i> <i>Day Type 4</i>		
Day Period 1	00:00 – 24:00	Tariff = T2

<i>Summer Season</i> <i>Week Type 1</i>	
Monday	Tariff Day Type 1
Tuesday	Tariff Day Type 2
Wednesday	Tariff Day Type 2
Thursday	Tariff Day Type 2
Friday	Tariff Day Type 3
Saturday	Tariff Day Type 4
Sunday	Tariff Day Type 4

multicube

Modular Metering System - Data Logger / Tariffs

8.2.4. Tariff Seasons

Up to 8 periods of each calendar year (seasons) may be defined by selecting start and end dates. A single **Tariff Week Type** is assigned to each season to define the tariff structure for the period.

Example: 2 Seasons (Winter and Summer) Using 2 Week Types

Tariff Week Type 1	
30 th November - 22 nd March (Winter)	Tariff Week Type 1
23 rd March – 29 th November (Summer)	Tariff Week Type 2

This structured approach simplifies setting of Tariff periods for a year while maintaining flexibility to suit most tariff structures.

8.2.5. Tariffs in the Data Logger

In addition to displaying kWh and kvarh accumulated during Tariff periods T1-T8 the **multicube** system records T1-T8 time periods relevant to each day in the data logger. This data does not affect the logged energy but provides historic tariff information locally in the unit. This information can be downloaded with the energy profile to produce historic tariff weighted energy data.

Each day the logger stores the Tariff Number for each period and the associated Tariff Value dependant on the tariff structure and calendar date.

9. Specification

9.1. Modular Metering System

ENVIRONMENT	
Temperature	Operating -10°C to +55°C Storage -25°C to +70°C
Humidity	< 75% non-condensing
Environment	IP54 standard
MECHANICAL	
Enclosure	Material: Black ABS UL 94-V0
Dimensions	Height : 164mm Depth: (Off Wall) 96mm Length: Master Display Unit: 100mm Communication Module: 29mm Dual Metering Slave: 29mm Master Display Unit: TBA Dual Metering Slave: TBA
SAFETY	
Conforms to	EN 61010-1 Installation Category III

multicube

Modular Metering System - Specification

9.2. Master Display Module

GENERAL		
Dimensions	Height :	164mm
	Depth: (Off Wall)	96mm
	Length:	100mm
System	1-Phase 2 Wire Unbalanced Loads 3-Phase 3 or 4 Wire Unbalanced Loads 2 Phase 3 wire Unbalanced Loads	
Modules (Capacity)	Maximum = 10 Modules e.g. 10x Metering Modules SM352	
Voltage Un	Nominal:	400V Phase to Phase 230V. Phase to Vn
	Terminals Rising Cage. 4mm ² (12 AWG) cable max.	
Current In	Nominal:	0.333V from Externally Isolated Custom Current Transducers.
Measurement Range	Voltage	40% to 120% of Nominal
	Current	0.2% to 120% of Nominal
Frequency Range	Fundamental	45 to 65Hz
	Harmonics	Up to 30th harmonic at 50Hz Individual to the 15th
Burden	Voltage	<0.1VA per phase
	Current	Not applicable (Burden fitted in transducer)
Overload	Voltage	x4 for 1 hour
	Current	x40 for 0.5 second max
DISPLAY		
Type	LCD 128x64 Dot Graphic	
AUXILIARY SUPPLY		
Input Range	90-264Vac 50/60Hz	
Load	Master Only :	TBA W max
	Master + 10 SM352 Modules:	TBA W max.

Modular Metering System - Specification

9.3. Dual Metering Module SM352

GENERAL		
Dimensions	Height :	164mm
	Depth: (Off Wall)	96mm
	Length:	29mm
Current Inputs: (1/2 Module)	Use only Northern Design Current Transducers with the following specification:	
	Nominal CT Primary: 20A;40A;60A;100A; 150A; 200A, 300A, 400A; 600A, 800A, 1000A or 1200A	
	Nominal CT Secondary: 0.333Vac Insulation Class 600Vac	
Voltage Input	From Master Display Unit: maximum 0V - 3.3V ac Peak	
ACCURACY All errors ± 1 digit		
kWh	Better than Class 1 per EN 62053-21 & BS 8431	
kvarh	Better than Class 2 per EN 62053-23 & BS 8431	
kW & kVA	Better than Class 0.25 IEC 60688	
kvar	Better than Class 0.5 IEC 60688	
Amps & Volts	Class 0.1 IEC 60688 (0.01In – 1.2In or 0.1Un – 1.2Un)	
PF	$\pm 0.2^\circ$ (0.05In – 1.2In and 0.2Un – 1.2Un)	
Neutral Current	Class 0.5 IEC 60688 (0.05In – 1.2In)	
POWER SUPPLY		
DC Power From Master Display	DC Power Supply:	3.3V DC
	Maximum Load Per Module (2 Meters) :	TBA W