

Installation and Connection

NOTE: The installation of this device must only be undertaken by a suitably trained and qualified electrician; all local safety standards must be observed. All work must satisfy Building/IEE Wiring regulations in force at the time. Work must be passed by an approved NICEIC member.

Fixing

The meter is intended to be used within an indoor environment and must be positioned away from sources of water, excess heat and humidity. If installing outside, the meter must be fitted within a weatherproof meter cabinet or similar IP rated box.

The meter should be fitted onto a level firm wall, meter board or cabinet. Several mounting points are provided as shown below.

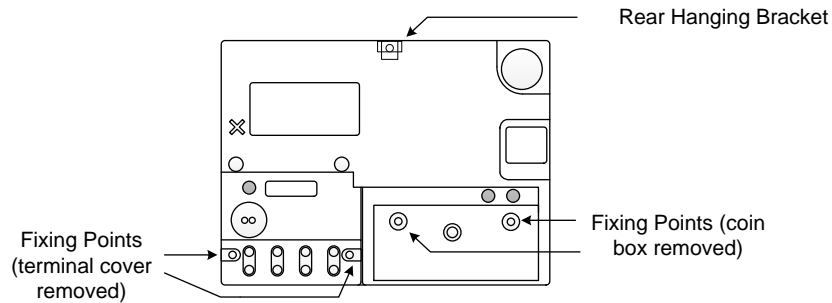

When installing the meter, initially it should be hung from the rear hanging bracket using a suitable round headed screw. The screw depth should be adjusted so the head fits snugly under the hanging point and the meter is held firm against the wall. Once hung, ensure the meter is level then mark and screw the meter to the wall securely using the four fixing points; two are located under the grey terminal cover and two are under the coin box (see drawing above).

Wiring

The meter is wired using the connections found under the grey terminal cover as follows:

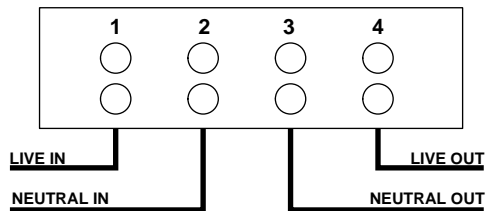

The meter must be protected against overcurrent. This is normally as part of the building installation (Service fuse to BS1361) or equivalent; maximum current through the meter must not exceed 100Amps.

Product Support

For further support or service please contact your local stockist.

Manufactured in the UK by EM-Lite Ltd

Unit 8, Jubilee Court, Copgrove, Harrogate, North Yorkshire UK, HG3 3TB



Camax UK Limited

01423 340 000

Operating Instructions

Coin Operated Meter/Timer

Model: MP11.z

Before use please read these instructions carefully

Thank you for purchasing an emlite coin operated meter. These instructions are intended to provide information on the installation, operation and programming of the meter. Please keep for future reference.

This meter is designed to be used for the control of the electricity supply in secondary metered sites such as Holiday and Landlord accommodation. The meter is fully approved to the European metering standard, MID (Metering Instruments Directive), the meter is therefore tested and approved as accurate for billing purposes. The meter may be used in a Prepayment Mode or Timer Mode.

Basic Features

The meter is available in different versions that allow £ or € coins to be accepted. In both cases the meter will accept 1 and 2 £/€ coins. The meter is also available in a version that accepts Tokens. Coins are inserted into the top coin hole as shown on the meter front. Any reject coins are returned from the chute below.

An electronic display indicates the amount of credit/time remaining. The display is also used for the programming of energy prices etc. The grey pushbutton next to the display allows the user to cycle through a set of displays showing their usage totals, rate prices and any set charges.

A coin box collects all accepted coins and should be secured using a 6 mm shank padlock (not supplied). Smaller sized padlocks will allow movement in the coin box and should not be used. Removal of the coin box is automatically detected and enables the programming function of the meter.

The meter is programmed using the two buttons found in the coin tray compartment. The programming function allows the energy price to be set and standing charge to be collected daily. A debt collection facility also allows a pre-set amount to be collected daily. The total amount for collection is programmed and the meter will reduce this each day by collecting monies from the users remaining credit balance.

A timer mode allows the meter to be used for control of appliances and services. A time period can be set for each coin accepted.

The consumption of energy can be seen using the red LED light below the display. The light flashes 1000 times for every 1kWh of energy used.

User Display Operation

Normal Operating Display

In Prepayment Mode the meter will show the amount of credit remaining to the user from coins inserted. Example: **Cr 3.50** means a credit of £3.50 or €3.50 is remaining.

In Timer Mode the meter will show the amount of time remaining to the user from coin inserted. Example: **00.02.30** means a time of 0 hours, 2 minutes and 30 seconds is remaining.

Alternatively, when all credit/time has been used the word **OFF** will be shown on the display and the supply disconnected. A red illuminated cross symbol also indicates supply disconnection.

When a coin is inserted and accepted by the meter **Coin in** will be shown on the display. The value of the coins accepted is added to the credit value.

Display Cycle

In Prepayment Mode a display cycle allows the user to look through their energy readings and see the prices & values set into the meter. The display list can be cycled using the grey push button to the left hand side of the display, each press of the button will move through the following example sequence. At the end of the display sequence **End** is shown. NOTE: there is no display cycle in Timer Mode.

t 00001.95 kWh	Total energy recorded by the meter since manufacture.
r1 00001.45 kWh	Energy Register for Rate 1. Amount of energy used at the Rate 1 price.
r2 00000.50 kWh	Energy Register for Rate 2. Amount of energy used at the Rate 2 price. NOTE: This display will only appear if the meter has been set for a 2 rate tariff where a different price is applied for part of the day e.g. day use, in Economy 7 type tariffs.
r1 022.78	Price charged in pence/eurocents. The credit value will be reduced by this value each time a kWh is consumed (while Rate 1 is active).
r2 015.93	Price charged in pence/eurocents for each kWh consumed (when Rate 2 is active). See note above.
st ch 25.00	Amount of standing charge being collected each day in pence/eurocents
dt ch 01.00	Debt charge. Amount being collected through debt collection each day. Value is in £/€.
dt t 015.00	Total amount of debt to be collected in £/€. Will reduce each day by the amount set in the Debt charge register until reduced to zero.

Programming

The meter is programmed using two push buttons accessed when the coin tray is removed. The buttons are shown in the diagram below and are described as A and B.

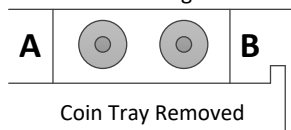

The A button is used to move through each display. When moving through a display the active (settable) number is shown flashing, the value of the active number can be increased using the B button.

Programming Display Cycle – Prepayment Mode

The programming cycle is entered by pressing button A. The first press activates a display test where all display segments are shown. Press the A button again to move to the first option, each following press of the A button moves through the following cycle one number at a time. Values shown below are provided as an example. PLEASE NOTE: Before changes are accepted by the meter, the complete cycle must be moved through until **End** is shown.

Func 1	Function Setting – Selects between Prepayment Mode and Timer Mode. 1= Prepayment Mode, 0=Timer Mode (see timer section below).
PC 0010	Program Counter - Number of the times the meter has been programmed. For information only, cannot be changed (included in timer mode cycle).
t Cr 0029	Total Credit- Total amount of cash accepted by the meter in £/€. For information only. Value is reset if meter cleared. (included in timer mode cycle).
CLEAR n	Allows the meter to be cleared e.g. for next occupant. Remaining Credit balance is cleared if set to yes - setting 'y' (included in timer mode cycle).
run 00:10	Timer Mode Run time - sets the amount of time in hours/minutes the meter will run for each 1 £/€ accepted (only shown in timer mode cycle).
15:35	Clock Time - allows the clock time of meter to be adjusted in 24hr clock format. NOTE: the meter does not automatically correct for daylight saving.
01.01.13	Date – allows the date to be set in the meter in the format dd.mm.yy.
r1 00:00	Start time when the rate 1 price becomes active in 24hr clock time. When only using a single tariff price, set time to 00:00.
r2 00:00	Start time when the rate 2 price becomes active. As an example set to 07:00 for Economy 7 day usage. When only using a single tariff price set time to 00:00 (Rate 2 is then deactivated and not shown in the user display cycle).
r1 022.78	Rate 1 Unit price - Price in pence/eurocents charged for each kWh consumed when rate 1 is active. Use the rate 1 price for single tariff pricing.
r2 015.93	Rate 2 Unit Price - Price in pence/eurocents charged for each kWh consumed when rate 2 is active (use for Economy 7 or similar type tariffs).
st ch 25.00	Standing charge – Amount to be collected every day as a standing charge. Set as pence/eurocents per day value.
db t 015.00	Total debt – Total amount of debt to be collected in £/€. The meter will automatically reduce the Total debt by the Debt charge amount each day.
dt ch 01.00	Debt charge - Amount of debt collected each day – used in conjunction with the total debt setting. The meter automatically reduces the remaining credit and total debt by the amount set in £/€ per day until the Total debt is zero.
r1 00001.45 kWh	For information - Rate 1 energy register.
r2 00000.50 kWh	For information - Rate 2 energy register.
t 00001.95 kWh	For information - Total energy recorded by the meter since manufacture.

Programming Display Cycle – Timer Mode

The meter can be programmed to act as a timer. The meter is put into Timer Mode using the Function Setting, a setting of 0 sets the meter to act as a timer. When set to timer mode the programming cycle will change, only the first five displays (as indicated above) are shown.